1200 D

CERAMIC | Diesel Stove



1200 D Stove

INSTALLATION, OPERATION AND SERVICE INSTRUCTIONS

2+1 year warranty at: wallas.fi/takuu
Download the latest version of manual at
<https://wallas.fi/documents/>

Safety - Safety Instructions for stoves	3
Technical information - Supplies and accessories	4
Technical information - Technical information	5
Technical information - Operation description	6
Installation - Stove installation	7
Installation - Fastening the stove	8
Installation - Waste heat	10
Installation - Connections of the device	11
Installation - Electrical connections	12
Installation - Electrical connections B	13
Installation - Camper/RV installation	14
Exhaust gas connections - Exhaust gas connections	16
Exhaust gas connections - Side lead-through 1066	17
Exhaust gas connections - Stern lead-through 5400	18
Exhaust gas connections - Closable lead-through 2466	19
Exhaust gas connections - Drainage lock 602293	20
Exhaust gas connections - Insulation kit 2461	20
Fuel connections - Fuel connections	21
Fuel connections - Fixed tank connection 30011	22
Fuel connections - Separate tank connection 367200	23
Fuel connections - Solenoid valve 30012	24
Fuel connections - Tank external filters 30015, 30016	25
Fuel connections - Tank connection 30018	26
Fuel connections - Selecting the fuel	27
Operation - Device operation	28
Control Panel - Control Panel Installation	30
Control Panel - Control Panel basic features for stoves	31
Control Panel - Connecting with the Remote application (stove)	35
Control Panel - Software update	39
Control Panel - Error Codes	40
Important information - Installation check list	42
Important information - Maintenance recommendations for stoves	44
Important information - Warranty terms	45
Important information - Disclaimers	46

Safety Instructions for stoves

Important Safety Instructions

!	This manual has information on product safety and instructions to reduce risk of accidents and injuries.
!	This stove (hereinafter also referred as "unit" and "device") is designed and intended for recreational use.
!	We recommend having a Wallas-Marin professional install our products to avoid improper installation that can cause injury or property damage.
!	Installation instructions in this manual and country-specific requirements must be followed.
!	It is the responsibility of the owner and the installer to determine which requirements and standards apply to specific installations.
!	Wallas-Marin offers a 2+1 year/2000 hour warranty. The warranty is not valid if the unit has not been installed according to the manual or the country-specific regulations have not been followed.
!	Do not repair, replace or remove any part of the unit unless specifically recommended in the manual. All other servicing should be done by an authorized Wallas-Marin Distributor or Service Center.
!	This unit is not intended for use by persons (including children) with reduced physical, sensory or mental capabilities (that could affect a safe handling of the product), or lack of experience and knowledge, unless they have been given supervision or instruction concerning use of the appliance by a person responsible for the safety.
!	As with any carbon-hydrogen combusted product, the vessel should be properly fitted with a CO detector, tested regularly and replaced as per the manufacturer's schedule. The installer must ensure there is sufficient ventilation into the indoor space for occupants and system operation.
!	Exhaust fumes are hot and toxic.
!	Wallas-Marin reserves the right to change or improve its products, and to modify appearances and specifications without notice.
!	Do not use the device while driving. This may cause exhaust gases to enter inside the vehicle.

Supplies and accessories

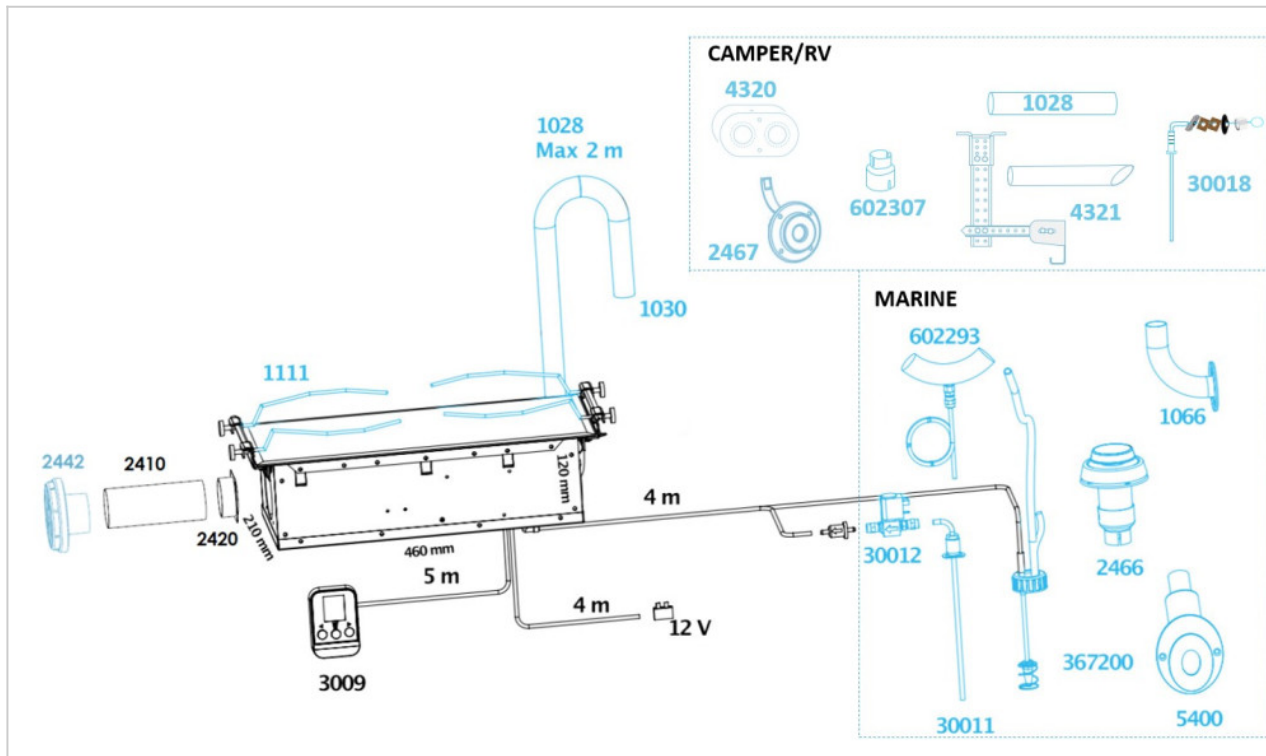

Package contents

1 pcs	Stove 1200D
1 pcs	Fuel hose (4m)
1 pcs	Power cable with connector (4m)
1 pcs	Control panel 3009
1 pcs	Warm air duct, \varnothing 60 mm 2410
1 pcs	Warm air duct adapter with collar, \varnothing 60 mm 2420
1 pcs	Accessory bag

List of supplies and accessories

General accessories	Boat Installation accessories	Camper/RV Installation accessories
1111 Pot holders 1028 Exhaust tube, \varnothing 28 mm 1030 Heat insulation, Fiber glass 2442 Outlet grill, \varnothing 60 mm	1066 Hull lead-through 2466 Sealable deck lead-through 30011 Tank fitting 30012 Magnetic valve 12V/0,5 A 367200 Lead through kit for separate tank 5400 Stern lead-through, \varnothing 28/45 mm 602293 Drainage lock	2467 Coaxial hull lead-through 4320 Cover plate kit 4321 Stove inst. kit for vehicles 30018 Tank connection, standard 602307 Adapter 28/45 mm

Technical information

1200D

Fuel	Diesel oil, light furnace oil, HVO-fuel HVO EN 15940, B10 EN 16734, D20/30 EN 16709
Operating voltage	12 V DC
Fuel consumption	0,1 - 0,22 l/h (3,4 - 7,4 oz/h)
Heating power	1000 - 2200 W (3,410 - 7,500 BTU)
Power consumption	0,37 - 0,55 A (7,5 - 10,5 A during start up)
Dimensions (L x W x H)	460 x 210 x 120 mm (18 7/64" x 8 17/64" x 4 3/4")
Weight	6,3 kg (13,9 lbs)
Maximum permitted length of exhaust pipe	4 m
Maximum permitted length of fuel hose	6 m
Minimum area of the replacement air opening	150 cm ²
Connections	Solenoid valve Remote control
Suitable Exhaust gas lead-throughs	1066, 2466, 5400
Recommended usage temperature	-15 -+30 Celsius Mandatory: Check your local fuel tolerance for freezing temperatures.

Due to physical laws of thermodynamics, Wallas-Marin announces measured values with 10 % tolerance.

Operation description

1200D is a safe single burner forced air diesel stove. It produces heat by a laminar combustion process, which requires air, fuel, and a glow plug for the ignition. Combustion air is drawn in with a combustion fan from inside the stove installation space. Main power is connected to the 12 V battery. Fuel pipe is connected to the main diesel tank or a separate tank. The highly precise dosing fuel pump delivers fuel to the burner from the diesel tank, glow plug switches on, air-diesel mixture ignites and creates combustion. The heat generated by the combustion process is transferred to the ceramic stove top. This whole process takes place inside a closed chamber, meaning there is no exposed flame. The power level (1-6) can be adjusted from the control panel, six being the hottest.

In the combustion chamber, the fuel vaporizes before ignition, resulting in nearly 100% combustion, making this technology one of the most environmentally friendly options for offgrid cooking and heating. In addition to fossil based diesel, the Wallas Greenboost burner burns renewable diesel (HVO) cleanly and efficiently resulting in ultra-low emissions. The exhaust gas is safely vented outside keeping the indoor air clean and odorless. The exhaust gas also carries the moisture in the indoor air out keeping the air dry and fresh.

The stove is air-cooled. The cooling air must be extracted from the installation space. The cooling system requires a replacement air opening to the installation space. Air-cooling allows one to mount the stove tightly underneath the countertop. The cooling air is sucked in from the same side as the exhaust gases are pushed out. Warm cooling air travels through the stove casing and is pushed out from the other end. This air can be vented outside the vehicle/boat/RV/building or inside as a secondary heat source.

The Wallas 1200D lends itself extremely well to cooking and warming up all kinds of foods. The flush-mounted compact cooktop is perfect for tasty meals in small spaces.

Stove installation

Saw a cut-out (see picture on the previous page) for the stove and the control panel in your chosen location.
The length of the control panel cable is 3m.

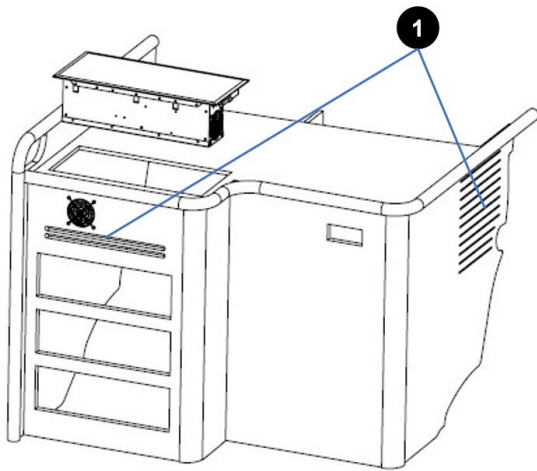

1. The stove requires a replacement air opening of at least 100 / 150 cm². Ensure that the air circulation under the stove is sufficient.

You can also fabricate a detachable panel to go in front of the stove. This will facilitate installation and maintenance.

Ensure there is sufficient space under the stove for cables and hoses.

The control panel should be installed on a vertical surface.

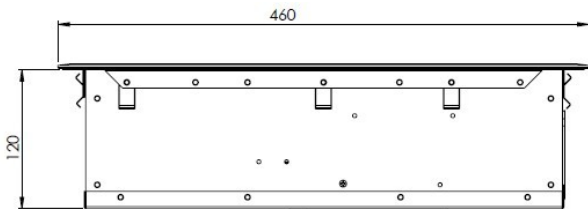

Dimensions of the equipment (120 x 460 mm)

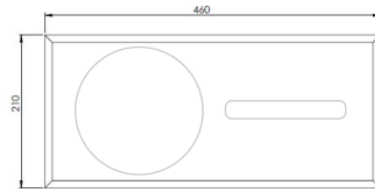

Dimensions of the cooktop (210 x 460 mm)

When installing the stove to closed table warm air duct must be installed to guide hot air out of the installation table. Warm air duct max length is 150 cm. Use only open grill.



Installation table should withstand min 90 °C temperatures.
Exhaust tube must be insulated inside the table.

Fastening the stove



The mounting surface must withstand at least 90 °C heat.

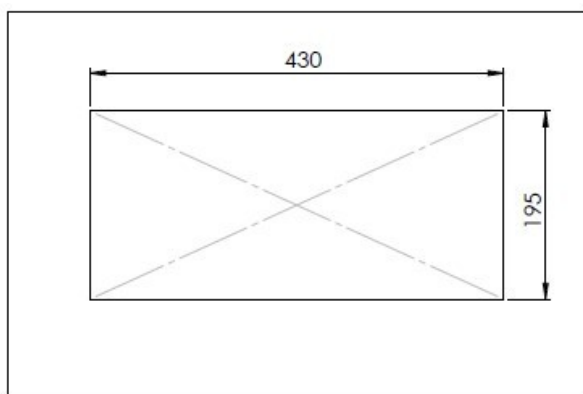

Choose a suitable place for the stove and make an installation hole in it as shown in the picture (195 x 430 mm).

Installation instructions without pot holders

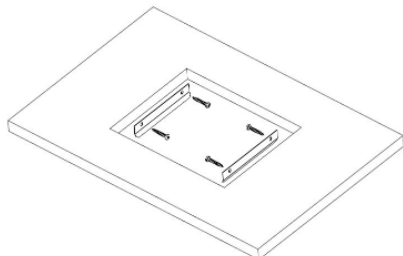

Install the cooker locking plates (2 pcs) with four screws (screws 4,8 x 32 mm).

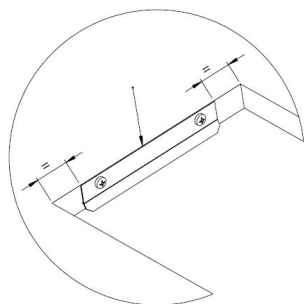

Install the stove's locking plates in the middle of the opening and the upper part at the same level as the surface of the table.

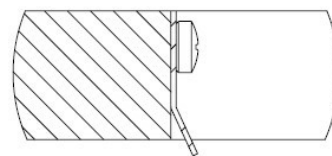

Locking plate installed. The locking plate must be turned towards the inside of the opening.

Installing the stove in place

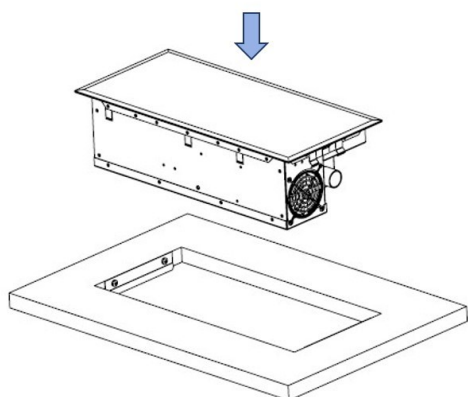

Finally, press the stove into place.

To remove the stove: Push the stove from the bottom up.

The stove must be installed as shown, exhaust away from the user.

Installation instructions with pot holders

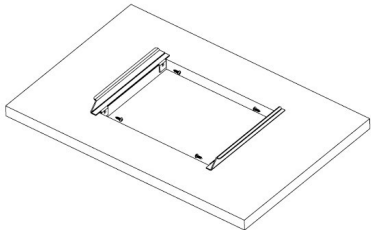
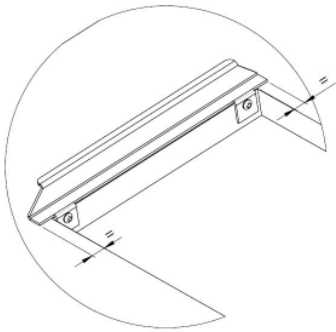
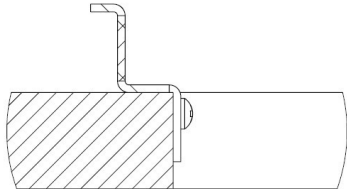
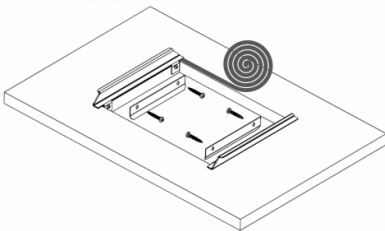
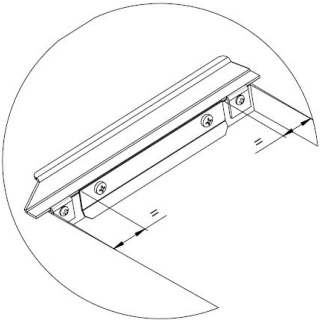
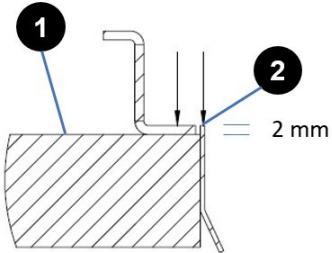
		
<p>First install the slide rails of the pot holders (2 pcs) with four screws (screws 5 x 16).</p>	<p>Install the slide rails for the pot holders in the middle of the opening.</p>	<p>Pot holder assembled</p>
		
<p>Install next the cooker locking plates (2 pcs) with four screws (screws 4,8 x 32 mm). Glue the sealing strip on the edge of the opening.</p>	<p>Install the stove's locking plates in the middle of the opening</p>	<p>1. The top surface of the table 2. The upper surface of the locking plate Install the locking plate so that its upper surface is at the same level as the sliding rail of the pot holder, i.e. 2 mm above the surface of the table. The locking plate must be turned towards the inside of the opening.</p>

Installing the stove in place

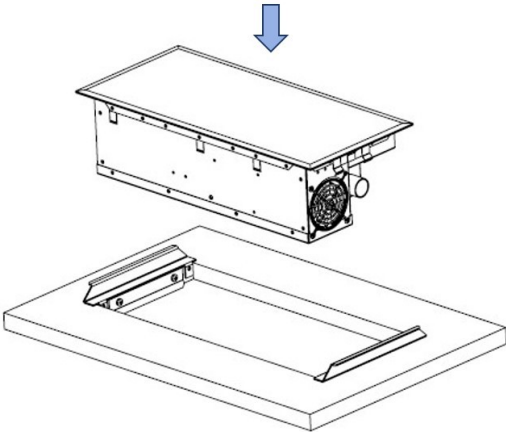
	<p>Finally, press the stove into place.</p> <p>To remove the stove: Push the stove from the bottom up.</p>
---	--

Waste heat

The 1200D stove is air cooled. The waste heat is removed from the installation space via warm 60 mm air duct **2410**. The air duct attaches to the stove's end, side or bottom with the adapter **2420**. The waste heat air must be removed from the installation space. The waste heat air can be directed inside the vehicle/boat/cabin or outside.

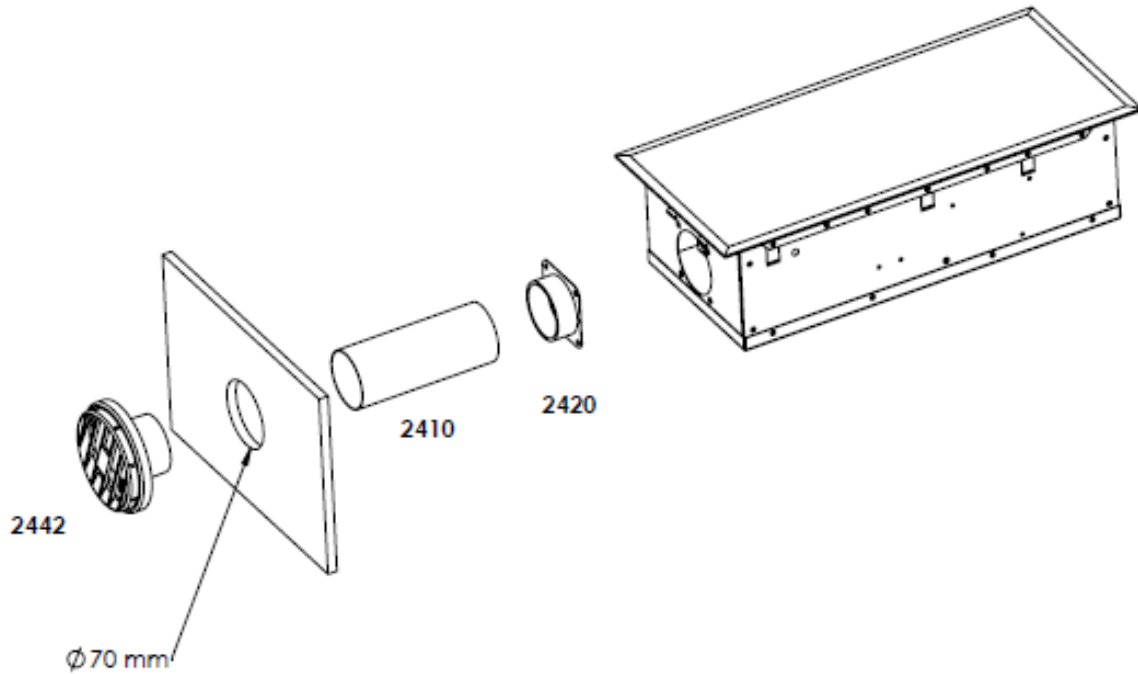

Connections of the device

Things to note about the connections

It is recommended to leave some extra length of loose cables and fuel line by creating a coil. This will make the mounting and demounting for service easier. If the installation location is cramped, it is recommended to connect the cables and the fuel line to the device before mounting the unit to the chosen location (for example on the table surface).



In metal-hulled boat, you must ensure that the device, the flue gas lead-through, the fuel connection, the control panel and all other parts are insulated from the boat's hull. This must be done to:

- prevent electrochemical corrosion
- prevent voltage from being transmitted from the hull to the device or vice versa during electrical faults.

Electrical connections

Safety instructions for wiring the stove



Make sure that electrical cables are not damaged. Avoid: chafing, kinking, jamming or exposure to heat.

Electrical connections and ground connections must be free of corrosion and firmly connected.

Things to note about the connections

All connections must be arranged in the craft so that they can function perfectly under normal operating conditions. Insulate unused cable ends.

The device uses 12 V (nominal) direct current voltage. To minimize current losses, make the power cable as short as possible and avoid joining. The cross-sectional area of the cable is dependent on the length of the power cords. The cross-sectional area of the cable should be consistent all the way from the device to the battery. The maximum length of the power cord is 10 m, based on 6 AWG cable.

The cross-sectional area of the cable

Total length of the power cord (m)	Minimum cross-sectional area of the cable in square mm (US Gauge)
0-4	2,5 (13 or 12 AWG)
4-6	6 (9 or 8 AWG)
6-10	10 (7 or 6 AWG)

If a thicker cable is required, make a separate joint in the power cord. See picture "Electrical connections of the device".



Never use the main switch to cut the power before the cooling phase, which starts after device is turned off, is completed.

Always use original Wallas accessories and parts with Wallas equipment.



In metal-hulled boat, you must ensure that the device, the flue gas lead-through, the fuel connection, the control panel and all other parts are insulated from the boat's hull. This must be done to prevent electrochemical corrosion and to prevent voltage from being transmitted from the hull to the device or vice versa during electrical faults.

Electrical connections B

Electrical connections from power system

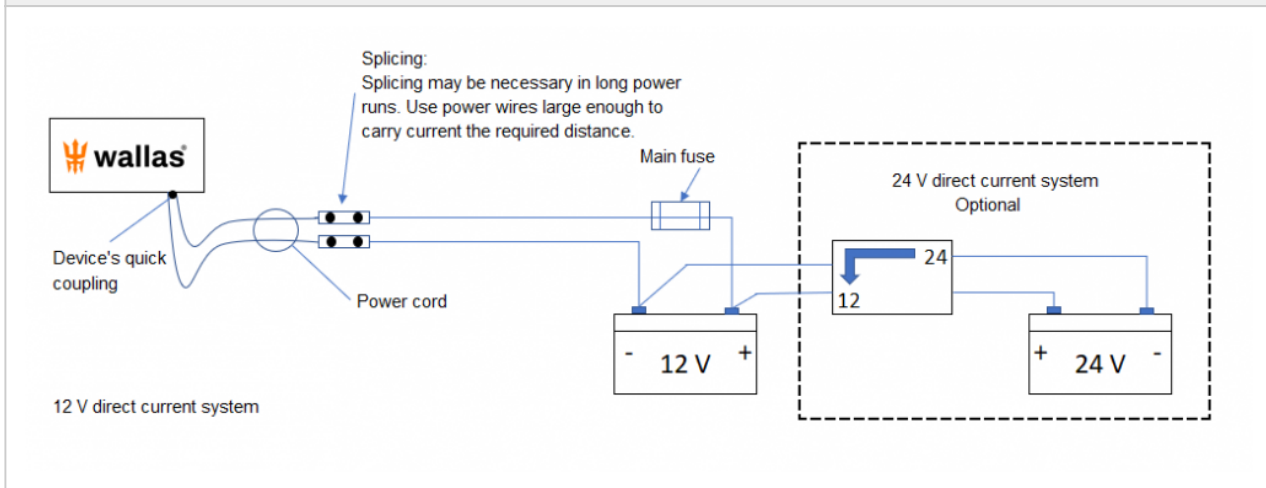

12 V direct current system

Connect the red wire of the power cord to the plus terminal of the battery and the black or blue wire to the minus terminal. A 15 A main fuse must be installed near the battery on the red plus wire of the power cord. See picture above.

24 V direct current system

If the device is to receive power from a 24 V system, always connect a charging voltage reducer through a 12 V battery before connecting the device as shown above.

Without the battery most voltage reducers will not be enough to generate the large amount of current the glow plug requires.

After the 12 V battery, the connection is the same as in a 12 V system. Note, if using remote wire, the remote wire also needs connection to 12V, not 24V.

For DC DC 24/12 converter ask recommendation from your local dealer. There are major differences between them, but typically a converter rated for 25A is required.

Checking the connection

The device consumes the most power when it is starting (glow on). At this time, voltage drop is at its highest. During the glowing phase, the voltage must not fall below 10 V measured at the quick coupling. See picture above. If the voltage is lower than this, the device may not start.





All wires should be mounted with smooth bending and equipped with strain relief.

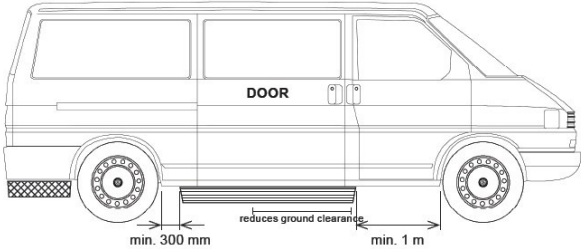
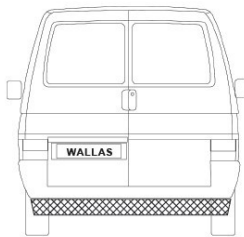
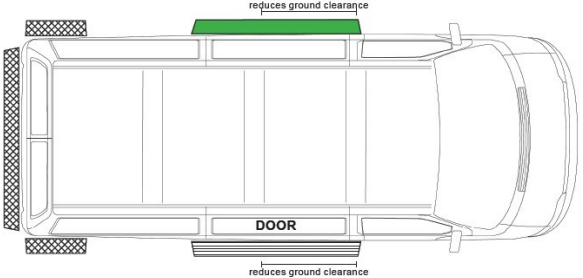
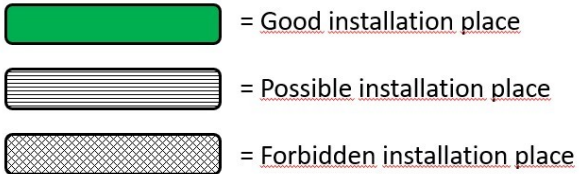

The device has to be connected to the service battery of the boat.

Camper/RV installation

Location of the exhaust gas hose

Location in the underframe	
	
	 <ul style="list-style-type: none">  = Good installation place  = Possible installation place  = Forbidden installation place

When selecting the location for installing the chassis installation kit (4310), the internal layout of the vehicle and routing of the exhaust gas and intake air hoses should be taken into account. Try to keep the hoses as short as possible. Also keep in mind that the exhaust gas hose becomes hot.

A free flow of air past the exhaust gas hose must be ensured at all times. Install the end of the exhaust gas hose on a straight surface, flush with the vehicle's side line. Avoid corners and cavities where wind pressure may disturb the unit's operation. Also bear in mind that when installed in the middle of the vehicle, the exhaust gas pipe will reduce ground clearance the most.

The minimum distance of the exhaust gas pipe from the fuel tank's filler hole is 400 mm (16").

The front edge of the exhaust gas hose must always be installed flush with the vehicle's side line, it must not be under the vehicle. The minimum distance from the rear tyre of the vehicle is 0.3 metres, while the minimum distance from the front tyre is one metre. The exhaust gas hose must not be installed at the rear end of the vehicle.

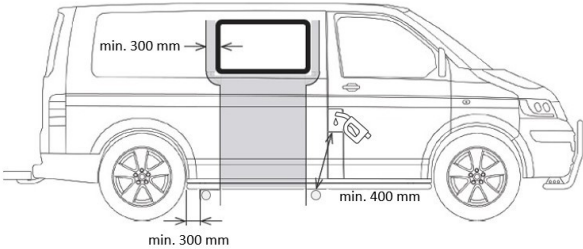
Location under a window	
	<p>The minimum distance of the exhaust gas pipe from the fuel tank's filler hole is 400 mm (16").</p> <p>The front edge of the exhaust gas hose shall not be installed under an opening window or closer than 300 mm to the window's edges. If the exhaust gas hose has to be installed near an opening window, the window must be prevented from opening or fitted with a switch that prevents the unit from being used when the window is open.</p>

! The minimum ground clearance shall not be exceeded. Make sure the exhaust hose does not touch anything flammable underneath the vehicle, for example grass. The hot exhaust might cause a fire. Make sure that there is open way to the point of jack up.

Installing the exhaust gas hose

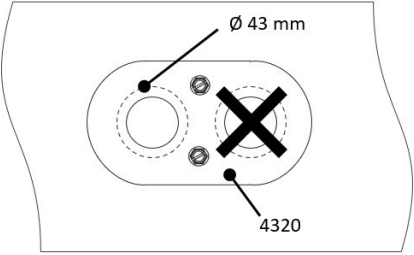
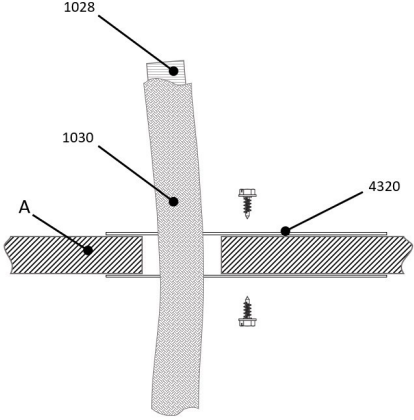
	<ol style="list-style-type: none"> 1. Drill one approximately \varnothing 43 mm hole for the hose, as illustrated. 2. Install the bottom penetration cover plate set (4320).
	<ol style="list-style-type: none"> 3. Insulate the exhaust gas hose (1028) with the fiberglass sleeve (1030). <p>If the floor structure of the vehicle at the location of the exhaust gas hose is not heat resistant, remove part of the insulation and replace it with heat-resistant material.</p>
<p>A Vehicle floor structure</p>	

Fixing to the vehicle bottom

There are many possible ways to install the exhaust gas hose to the vehicle's bottom structure. The basic chassis installation kit (**4321**) can be used to install the exhaust gas frame to most vehicles. Installation kit for vehicles is sold separately.

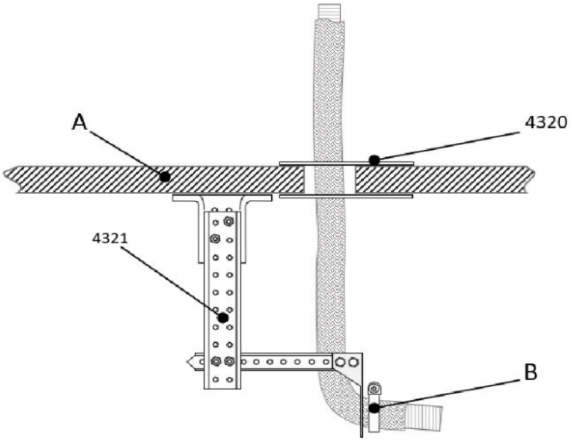
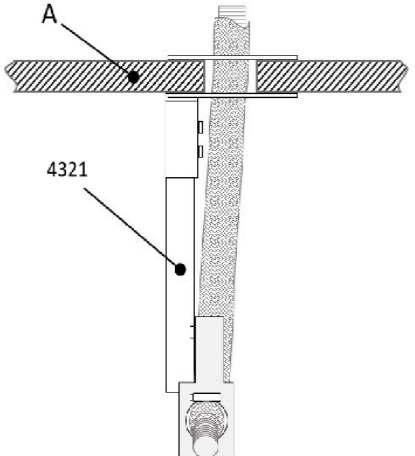

	
<p>A Vehicle floor structure B Hose clamp 20-32 mm</p>	<p>A Vehicle floor structure</p>

Exhaust gas connections

Exhaust gas lead-throughs

Exhaust gas lead-throughs **1066** for side installation, **5400** for stern installation and the closable model **2466** are suitable for singular exhaust. \varnothing 28 mm lead-throughs fit the exhaust gas pipe **1028**. All exhaust gas lead-throughs are stainless steel.

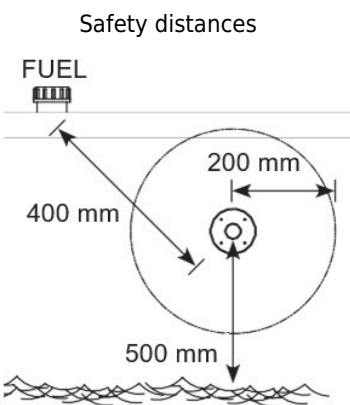
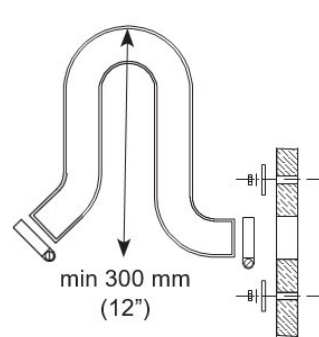
The exhaust gas reaches a high temperature! Be sure that the tube does not touch flammable materials and double check the connections. Insulation sock **1030** is available as an accessory.

<p style="text-align: center;">Safety distances</p> 	<p style="text-align: center;">Location (boat installation)</p> <p>Air must always flow freely past the lead-through. Install the lead-through on a flat surface. Avoid corners or recessions where wind pressure can disturb the functioning of the device. The minimum distance of the lead-through from the fuel tank's filler hole is 400 mm (16"). The minimum distance of the side lead-through from the surface of the water is 500 mm (20"). Especially in sail boats it should be noted that the lead-through must never be submerged. It is recommended to place the lead-through in the side as far back as possible or directly in the transom.</p> <p>Never place lead through near cabin fresh air intakes. Make sure that exhaust gases can never mix into fresh air intake.</p>
<p style="text-align: center;">Goose neck</p> 	<p style="text-align: center;">Installation (boat installation)</p> <p>When preparing the installation cut-out for the lead-through, it is a good idea to use the lead-through as a model for the cut-out; especially if the lead-through is circular. If necessary, seal the installation cut-out with silicone in addition to the lead through seal. Note! Do not use silicone on a wooden boat. The side lead-through must always be equipped with a so-called goose neck section. The goose neck will effectively prevent splash water from getting to the device. The highest point of the goose neck must always be above the surface of the water. The device will go out, if the exhaust gas lead-through is submerged.</p>
	<p style="text-align: center;">Other things to note (boat installation)</p> <p>Exhaust gas is hot. Always ensure that there is nothing that is susceptible to heat damage within 200 mm (8") of the effective area of the exhaust gases (e.g. ropes, fenders or the side of another boat). All lead-throughs raise the temperature of their surroundings. A wooden deck, in particular, may dry due to the heat. Remember that the surface of the lead-through is hot during use. An exhaust gas tube with a length of more than 2 meters (7') has to be equipped with a drainage lock 602293 (condense water) located to the lowest point of the tube. The exhaust gas pipe must be made of stainless steel. If necessary, seal the connections between the exhaust gas pipe and the lead through with heat-resistant silicone. When installing the lead-through to the stern side or to otherwise leaning position, be sure that the water do not stuck the exhaust. In metal-hulled boat, ensure that the device, the flue gas lead-through, the fuel connection, the control panel and all other parts are insulated from the boat's hull.</p>

Side lead-through 1066

Side lead-through 1066

A side lead-through is installed in the side of the boat or in the transom. In sail boats it is recommended to install it in the transom. The installation always requires a so-called goose neck piece. Make the necessary installation cut-outs and spread a suitable sealing agent on both sides of the seal and on the screw holes. This will ensure that the connection is waterproof.

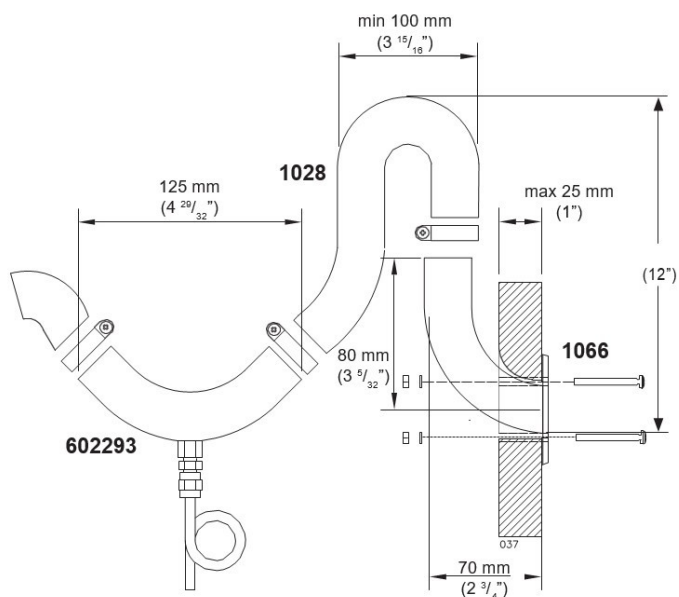

Side lead-through 1066 installed. The installation cut-out is \varnothing 35 mm and the screw holes are 4 x \varnothing 5 mm.



The exhaust tube will become extremely hot. Take care that the exhaust tube doesn't touch any materials which are sensitive and secure all lead-throughs. The exhaust tube can be equipped with a special isolation, art. No 1030. In 76D, 77D and 79D ovens use 1031 and 1051 due to higher exhaust gas temperatures.

Stern lead-through 5400



Installation instructions

Follow instructions for the exhaust gas lead-throughs.

Exhaust lead through for negative transom. Designed especially for sail boat's stern.

Closable lead-through 2466

Closable lead-through 2466

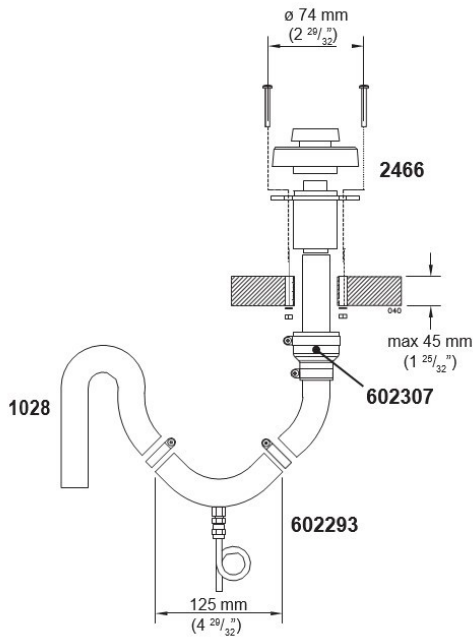

The cap of the closable lead-through must be detached for installation and seal maintenance by pressing the spring indicated by the arrow in with, for instance, a screwdriver. Take care not to let the screwdriver slip as the spring is very stiff. Hold the cap with your other hand when pressing in the spring. When the spring is down, pull the cap gently out of the frame. When assembling the lead-through, ensure that the order of the parts is correct. Also make sure that the spring goes in the correct hole in the cap. Otherwise, the lead-through cannot be closed.

Installation of the closable deck lead-through 2466. The installation cut-out is \varnothing 50 mm (2") and the screw holes are 4 x \varnothing 6 mm.

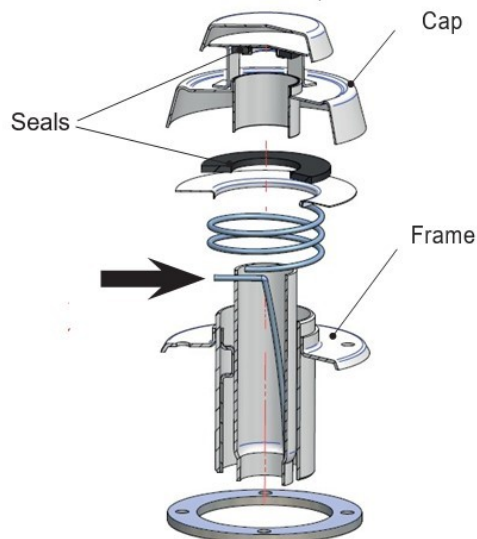
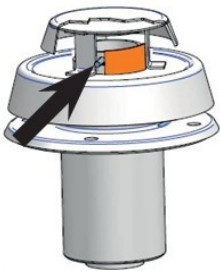

Maintenance

To keep the seals from hardening, lubricate them yearly with a heat-resistant petroleum jelly.



Check that closeable fitting is open before starting the device.

Drainage lock 602293

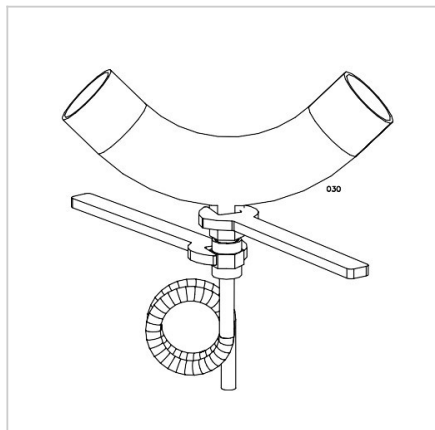

It is recommended to use drainage lock in deck lead-throughs and in over 2 meter (7') long exhaust gas tubes (ø 28 mm). This is to remove splash water and condense water.

If desired, it is possible to install a drainage lock to the exhaust pipe (ø 28 mm) of a hull lead-through, but then the drainage lock must come after the goose neck.



When washing the boat with a pressure washer, never aim the water jet at the lead-through as the device may get wet.

Insulation kit 2461

An insulation kit (**2461**) must be used to insulate the lead-through from the boats metal hull. The insulation kit insulates the exhaust gas lead-through and the device from each other. In fault situations the insulation kit prevents electric circuit running between the metal hull and the device. This could result the oxidation or malfunctioning of the devices circuit board and the circuit board would be damaged.

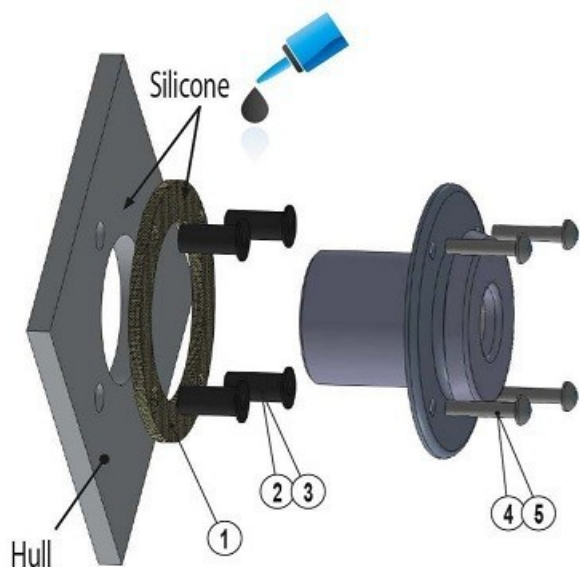

2461 insulation kit includes:

Part #	Definition	Amount
1	Gasket	2 pcs
2,3	Rubber nut M5 x 0,8 x 39,8	4 pcs
4,5	Screw M5 x 40 A2	4 pcs
	Installation instructions	1 pcs

Fuel connections

Things to note about the connections

The standard length of the supplied fuel hose is 4 m (max 8 m). Cut the fuel hose to a length suitable for installation.

The lift height of the pump should be less than 2 m; preferably 0.5-1 m. The fuel pipe must always have a Wallas filter, either in-line or in the fuel tank. Only one filter should ever be in the system. The fuel filter can be installed either near the device, near the tank, or in another location where it can be easily checked and replaced, when necessary.

Diesel engine fuel filters and/or separators are not approved for use. All soft connections should be made with rubber or silicone hose which is resistant to fuel. When joining with rubber connectors, tubing ends should butt against each other.

Fuel lines other than those supplied by Wallas should be small bore (2-3mm) and must be qualified for suction use. Typical rubber fuel hose is not qualified for suction use, having a soft, collapsing inner wall lining. Please contact your Wallas dealer/distributor if non-standard fuel lines are being considered.

Country-specific requirements

The standard fuel hose is plastic. Please observe country-specific requirements with regard to the material of the fuel hose/pipe and the fuel filter. The inner diameter of a new replacement hose should be equal to the inner diameter of the plastic hose. Copper pipe **300692** and metal filters **30016** are available as accessories. Ask local requirements from your distributor.

Fuel feed

If the lift height exceeds 2 m, the fuel feed must be checked and, if necessary, adjusted.

The fuel feed must also always be checked, if parts of the fuel system, such as the pump or the electronics card, have been replaced. Fuel system adjustments are device specific. These adjustments should only be carried out by an authorized service shop.

Connection to a fixed tank

The Wallas device must have a dedicated (not shared) connection with a fuel filter outside the tank.

Connection to a separate tank

Cap run-throughs and sintered in-tank filters are used on plastic tanks. The fuel tank should be mounted securely. The fuel tank should be placed close to the keel line.



The fuel connections must be tightened firmly so that the air cannot leak into the hose. Always check the cleanliness of the connection surfaces before tightening. Air leaks in the fuel system will cause the device to malfunction.

Fixed tank connection 30011

Installation instructions for tank connection 30011

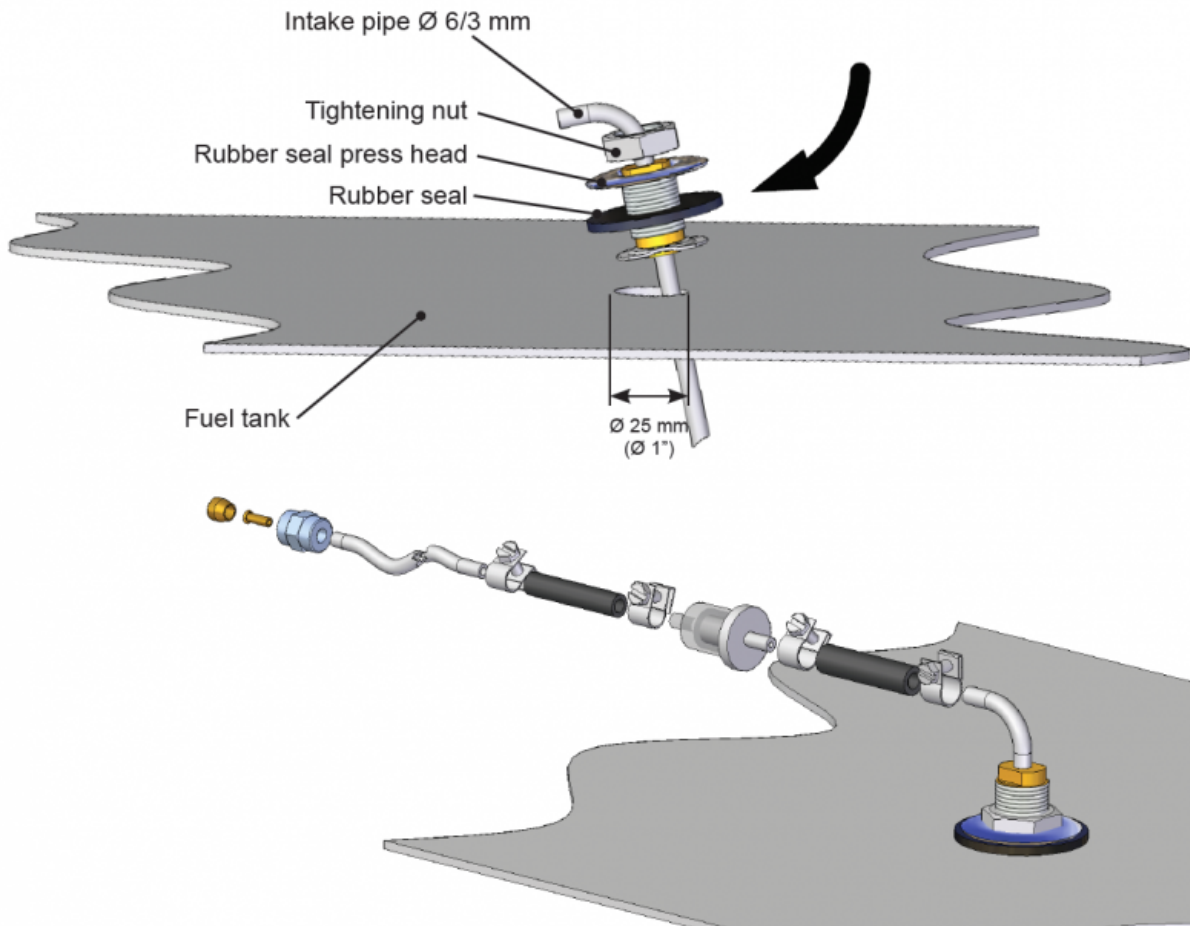

1. You will need to make a \varnothing 25 mm (1") hole in the upper surface of the fuel tank. Choose the location of the hole so that when the fuel tank tilts the end of the intake pipe will stay in the fuel even if the tank is not full. If the end of the intake pipe does not reach the fuel, the device will quickly choke on the air in the fuel system and that can cause malfunction to the system.
2. Cut the fuel intake pipe (\varnothing 3.2/0.8 mm) to the appropriate length. The end of the pipe must not touch the bottom of the tank in order to keep water and sediment from the system. It is recommended to cut the pipe short enough to leave the engine intake pipe at a lower level. This way the device cannot empty the tank.
3. Install the pipe straight end first and angle the two "ears" at the bottom of the threaded barrel inside the hole and then align the threaded barrel vertically so the ears are hooked on the underside of the tank top. Carefully slip the rubber washer over the bent pipe end and over the threaded barrel, followed by the metal washer and the nut. Thread the nut to the threaded barrel and tighten, sealing the fitting to the top surface of the tank.



If the device uses the main tank of the boat, note that the device cannot take the fuel from the same fuel output line as the engine of the boat.

Separate tank connection 367200

If the fuel will be taken from a separate tank, a tank connection **367200** must be installed.

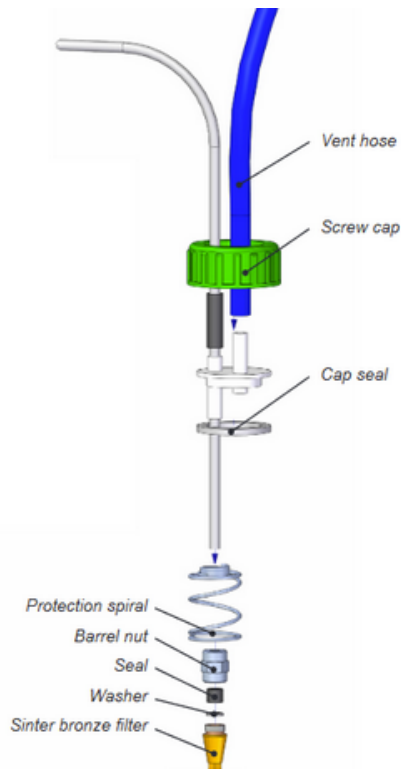

Wallas fuel tanks

Wallas fuel tanks are sold as accessories.

Volume	Length x height x width	WALLAS code
5 l	200 x 300 x 130 mm	2024
10 l	380 x 195 x 210 mm	2027
33 l	500 x 230 x 350 mm	4030
130 l	800 x 400 x 600 mm	4130

Solenoid valve 30012

The solenoid valve **30012** (available as accessory) prevents the tank from emptying in case the fuel system fails. The fuel filter should be installed before the solenoid valve.

Our recommendations in the following installation configurations:

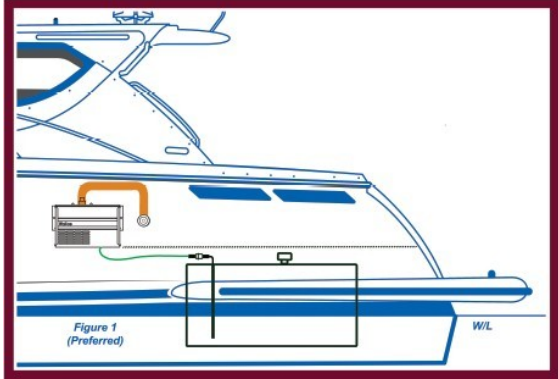
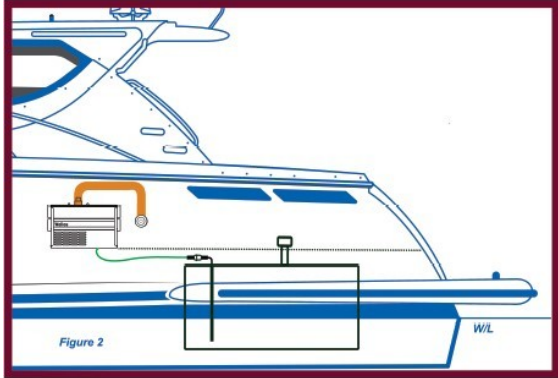
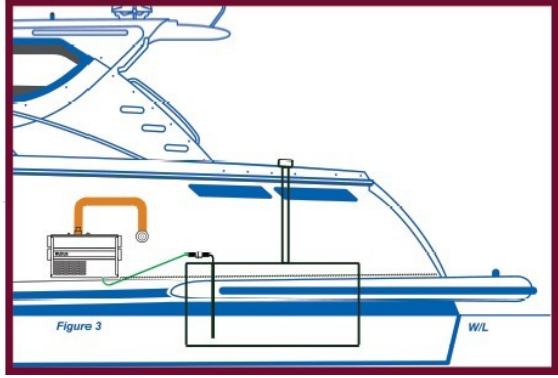
<p>Preferred installation layout (solenoid valve 30012 is not required)</p>	 <p>Figure 1 (Preferred)</p>
<p>Solenoid valve 30012 is recommended</p> <p>2. Fuel level may temporarily rise above the heater/stove (e.g. in the fuel tank filler pipe or when the boat tilts). See figure 2.</p> <ul style="list-style-type: none"> • No special accessories required but solenoid valve 30012 is recommended. 	 <p>Figure 2</p>
<p>Less desirable installation arrangement (solenoid valve 30012 must be installed)</p> <p>3. Fuel level is above the heater/stove. See figure 3.</p> <ul style="list-style-type: none"> • Less desirable installation arrangement • Possible siphon problem • Solenoid valve 30012 must be installed in the fuel hose near the tank. 	 <p>Figure 3</p>



If the fuel level in the tank is above the device, a solenoid valve 30012 must be installed in the fuel line immediately after the tank lead-through.

Tank external filters 30015, 30016

Assembly instructions

Filters can be installed in a \varnothing 5 or \varnothing 6 mm plastic tubing or 1/8" metal pipe. Ensure that the fuel pipes are clean before installing the filter. There must be no debris or impurities between the pump and the filter as they will clog the pump. The filter type must be selected according to the operating conditions and country-specific requirements.

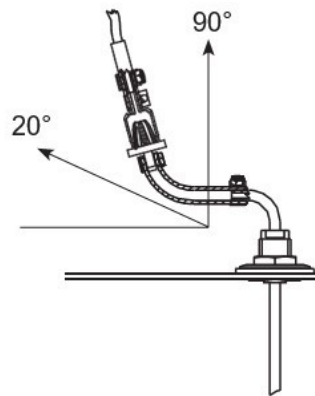
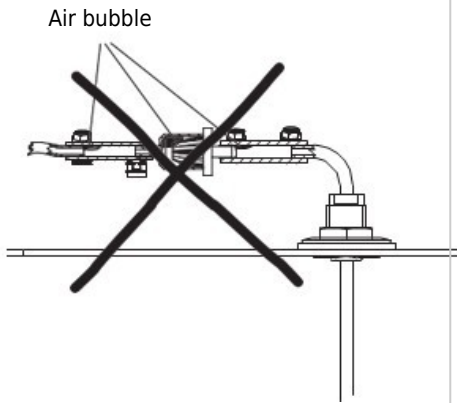

Fuel filter 30015

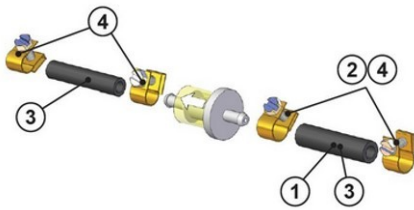

The filter is supplied with the device.

The filter can be installed directly in the **30011** tank connection by using a \varnothing 6 mm rubber hose (1) and 10 mm hose binders (2). Alternatively, the filter can be installed between two \varnothing 5 mm fuel hoses with \varnothing 5 mm rubber hose (3) and \varnothing 8 mm hose binders (4).

Install the filter in the direction of the arrow on it.

Fuel filter 30016 (accessory)

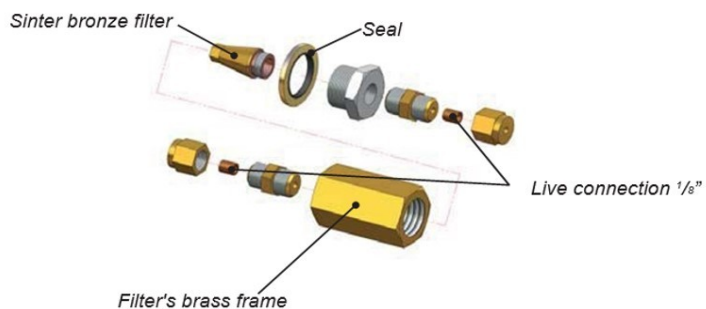

This filter is used in countries where a metallic fuel transfer system is required. A 1/8" metal pipe is used for the installation.

Tank connection 30018

Einon® (30018) is a leak-proof intake fuel line.

Getting Started

Parts needed in installation are put in right order and are connected together with a wire. You shall never cut the installation wire, you'll need it when installing the intake pipe. (Installation without the wire is not possible).

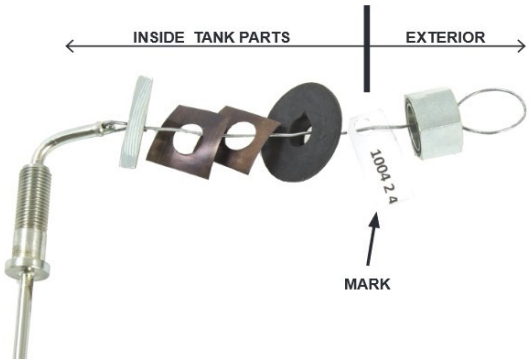
	<p>Installation instruction for 30018 (camper installation)</p> <ol style="list-style-type: none"> 1. Make sure that the fuel tank is empty enough. 2. Search about 4 cm flat section from the fuel tank where you can drill a 13 mm diameter hole. 3. Clean the selected area of protection grease and clean also other possible dirt. 4. Drill a hole. 5. Remove the burr from hole (inside and outside). 6. Figure out without installing for Einon ® (30018) suitable bending and length. The tip should be 10-20 mm above the tank bottom. 7. Cut the pipe end diagonally and remove burrs. 8. Install the cut and bent intake pipe through the drilled hole into the tank. 9. Push through the hole into the tank all the other interior parts (up to the mark), keep the order of parts as they are mounted to the wire. 10. Pull from the wire until the Einon ® (30018) threaded part is outside of the tank. 11. Turn the Einon ® (30018) to the correct position and tighten the tank external part (nut). 12. Attach the fuel line to the Einon ® (30018).
--	---



For camper installation only! Materials are not stainless steel.

Selecting the fuel

When selecting the fuel type, pay attention to the temperature limits of each particular fuel. The limit values provided here are to be treated as guidelines. Confirm the actual temperature limits from your local fuel supplier.

- HVO-Diesel, Diesel, summer grade, temperature must not fall below -5 °C.
- HVO-Diesel, Diesel, winter grade, temperature must not fall below -24 °C.
- Diesel, arctic winter grade, temperature must not fall below -40 °C.

If the temperature drops lower than the minimum level, paraffin may form in the fuel. This may result in the fuel filter and pump being clogged. The clog will dissolve only if the fuel temperature rises clearly over 0 °C.

For fuel additives and life length of the fuel ask information from your fuel supplier.

Recommended fuels

As one of the leaders in ultra-low-emission burner technology, Wallas is committed to clean combustion processes.

With our laminar flow Green Boost burner technology and adaptive software, our burners have ultra-low emissions, including exceptionally low CO₂ and NO_x levels.

All Wallas-Marin diesel heaters and stoves use diesel, renewable diesels (HVO 15940), or paraffin oil (kerosene) as fuel.

These include:

Today's road and boat diesels (EN590), renewable (HVO 15940).

We don't recommend the use of FAME (Fatty Acid Methyl Esters) fuels.

The methyl esters in biodiesel are hygroscopic. This means that they can absorb considerably more moisture than petroleum-derived diesel and hold this in suspension in the fuel. Petroleum-derived fuels absorb considerably less moisture by comparison and tend to shed water as a separate layer at the bottom of storage tanks. When water is able to contaminate diesel, it provides conditions suitable for microbial growth and can lead to diesel bugs, molds, yeasts and bacteria spreading throughout the fuel. FAME is bio-degradable and is an ideal source of nutrients for microbes. If contamination is left untreated, it can damage the fuel permanently.

Source: <https://www.crownoil.co.uk/guides/fame-biodiesel-guide/>



Confirm the actual temperature limits for the fuel you are using from the fuel supplier.

Device operation

Ignition

The stove turns on and heats automatically. The stove turns on when the power switch is pressed and starting light is orange.

A combustion indicator "flame" will be lit when the burner flame has been ignited and the combustion has stabilised after about five minutes after the ignition. The total time of starting procedure is app. 5-6 minutes.

Normal use

The power is adjusted manually. The cooker will ignite in manual mode.

After the ignition power can be adjusted 1-6 (6 is highest).

It is recommended to use cooking area 1 for boiling and cooking area 2 for stewing.

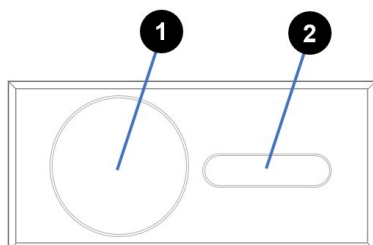

Shutdown

You can shut down the stove by pressing the Select Button from the Control Panel more than 2 seconds. Stopping process includes cooldown period and it takes over 10 minutes before hot indicator led is switched off. During the cooldown the stove fan is operating.

Blower lid

By lowering the blower lid to the horizontal position, the stove works as a cabin heater. Adjustment of heat control works either manually or with the help of control panel built-in thermostat.

Cleaning and maintaining the stove top

In order to keep the stove top in good condition both aesthetically and performance-wise, it should be cleaned regularly; preferably after each time of use. First scrape of the clearly noticeable dirt and food scraps with a cleaning spatula. Put a few drops of the cleaning agent for ceramic surfaces on the stove top and wipe it with a piece of kitchen paper. Then wipe the stove top with a moist cloth and dry it with another cloth. Do not use abrasive cleaning sponges or agents. Additionally, avoid using chemically strong cleaning agents, such as an oven cleaning spray or stain remover. Immediately clean off aluminium foil, plastic, sugar or other sugary substances that have melted on the stove top. This prevents the surface from getting damaged. Before cooking particularly sugary foods, the surface should be treated with a protective agent. This prevents possible damage due to the food boiling over. Observe the general maintenance recommendations for Wallas equipment when servicing the electronic and mechanical parts of the stove.

Things to note about the use of the cooking plate

Use only dishes with a smooth bottom so as to not damage the stove top. If you use the cold stove top for other work or chores, be sure to wipe it clean thoroughly after you are done. Even a small crumb, if hard enough, can scratch the surface when a kettle is placed on the stove top. These small scratches, which are to some extent inevitable, will in no way affect the heating power of the stove.

Make sure to use pots and pans with a flat, machined sandwich-style bottom that are made for use on ceramic cooktops. Steel, copper, enamel pot bottoms and pots for induction are forbidden. They may harm the stove and do not work optimally with the Wallas stove.

Please follow the markings



in pots, casseroles and pans.

Control Panel Installation

3008 and 3009 Control Panel cable can be assembled as a surface mount or behind wall.

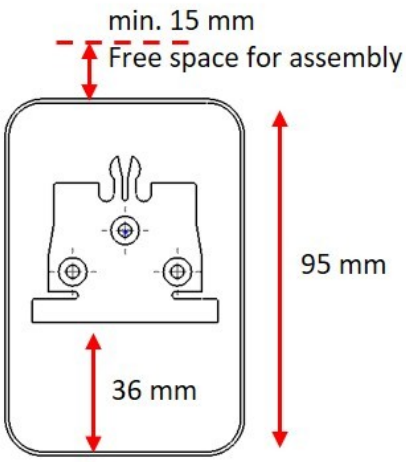
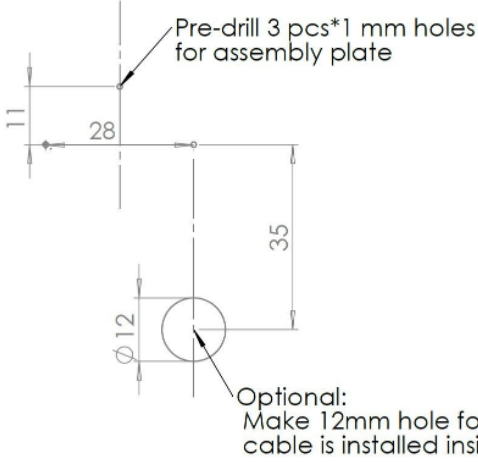
Surface mount, cable visible	Cable hidden behind the wall
	<p>Install assembly plate to flat surface.</p>  <p>Pre-drill 3 pcs*1 mm holes for assembly plate</p> <p>Optional: Make 12mm hole for cable if cable is installed inside wall .</p>
<ol style="list-style-type: none"> 1) Install the mounting plate and mark places for the screws. Pre-drill 3*1 mm holes for screws. 2) Cut the cable opening in bottom of the panel. 3) Install the mounting plate. 4) Slide the panel in place from the top down. 5) Remove the display protection tape. 	<ol style="list-style-type: none"> 1) Install the mounting plate and mark places for the screws. Pre-drill 3*1 mm holes for screws. 2) Drill 12 mm hole for the cable. Draw and check hole location before drilling, it should not be visible when panel is mounted. 3) Install the mounting plate. 4) Slide the panel in place top-down. 5) Remove the display protection tape.

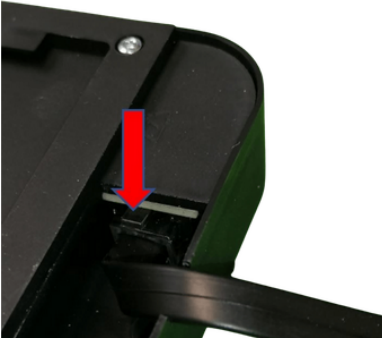
	<p>Cable connection</p> <p>Please note that cable connector release pin is positioned as in the picture, when connecting cable into panel. (Soft "click" sound can be heard when cable is connected.)</p>
	<p>Cable release</p> <p>Press connector release clip (shown in the picture) before pulling the cable out.</p>

Control Panel basic features for stoves

Advanced Control Panel

Before using the Advanced Control Panel ensure it is assembled correctly with the assembly plate (see assembly instructions from sales package) and connected to the Wallas unit.

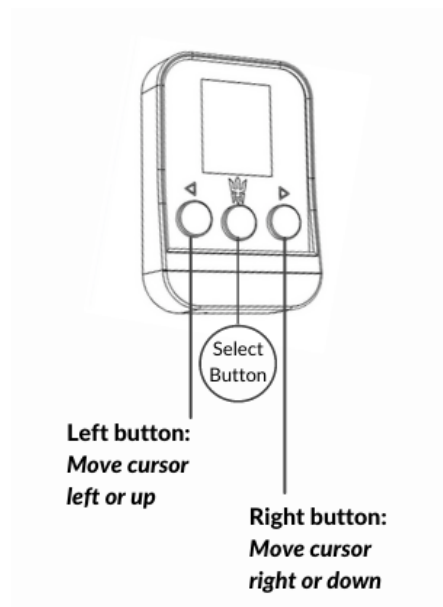

Note: Wallas unit's starting procedure will take approximately (5-8 minutes).

Digital panel legend	
	<ul style="list-style-type: none"> 1 Main Menu Bar 2 Power level 1 - 6 3 Stove status 4 Start/Stop Icon (white Icon Off, orange Icon On) 5 Info bar: Power On/Off, Combustion, Info, Lock, Stove power %

Starting the device in Manual control mode

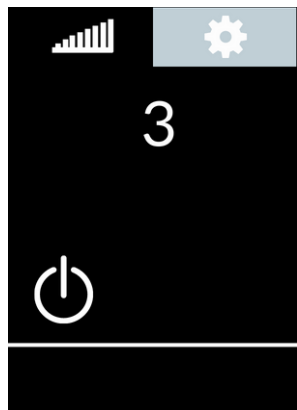

Home screen

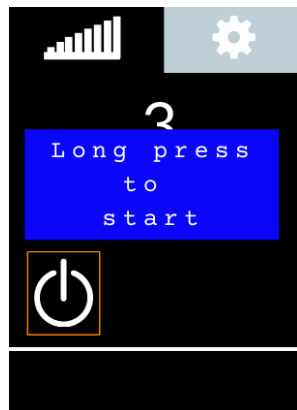

To start, use the **Arrow Buttons** (left or right) to move the orange selection square to the white **Start/Stop Icon** and press the **Select Button**. Confirm the selection by holding the **Select Button** down for 3 seconds (safety feature). White Icon turns orange.



Starting will appear on the screen. The light orange combustion light will light up when the burner flame has been ignited and the combustion has stabilized (in about 5 min). Stove will be fully operational about 10 min later.

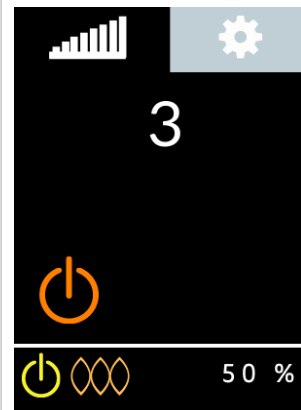

Move the selection square to the Power Level and press the **Select Button**. Use **Arrow Buttons** to set the desired power level (1-6).

Power level setting

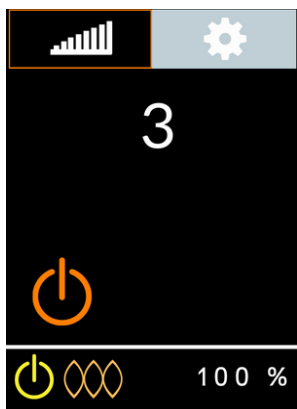

Use the **Arrow Buttons** (left or right) to move the orange selection square to the **Main Menu Bar**. Press **Select Button** to activate the the **Main Menu Bar**. Use **Arrow Buttons** to choose the **Manual Mode** and press the **Select Button** to select.

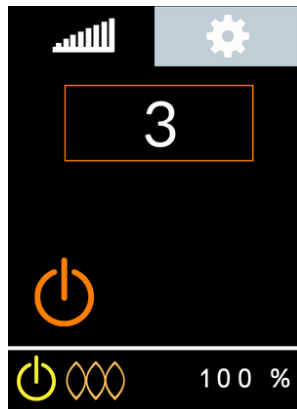

Use the **Arrow Buttons** (left or right) to move the orange selection square to the **Power level** and press the **Select Button**.



Press **Arrow Buttons** (left or right) to set the desired power level.
- power levels 1-6 (6 is highest)

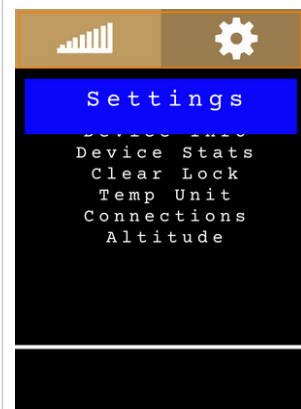



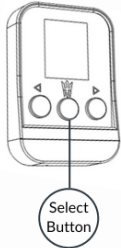
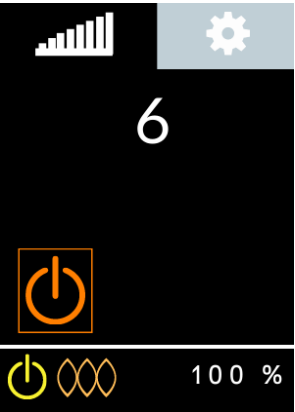
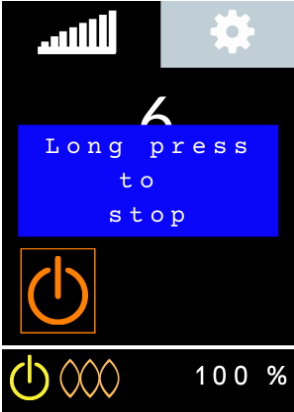
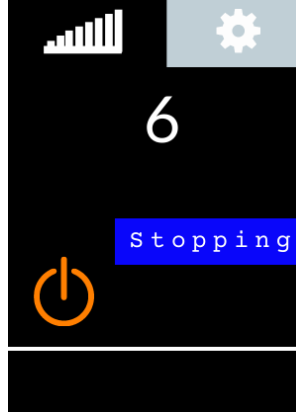

Settings
- get familiar with the control panel's functionality
- read more under Settings

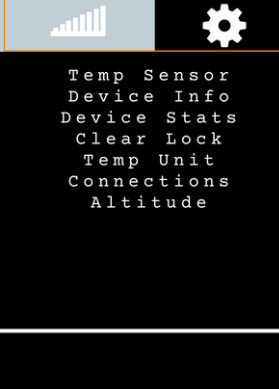
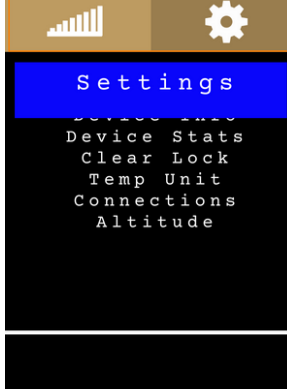
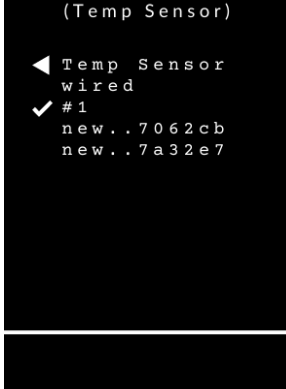
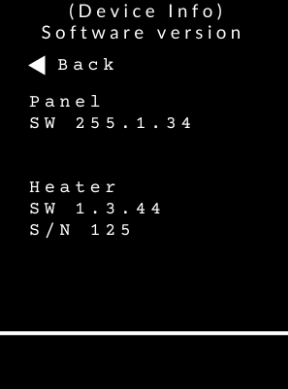
Shut down			
			
<p>Option 1 Quick shut down: Press and hold the Select Button down for more than 4 seconds. <i>Stopping</i> will appear and the Power Icon light will change to white indicating the unit is off.</p>	<p>Option 2 Alternatively use the Arrow Buttons to move the selection square to the Start/Stop Icon and press the Select Button.</p>	<p>Press and hold the Select Button down for more than 2 seconds.</p>	<p><i>Stopping</i> will appear and the Power Icon light will change to white indicating the unit is off.</p>

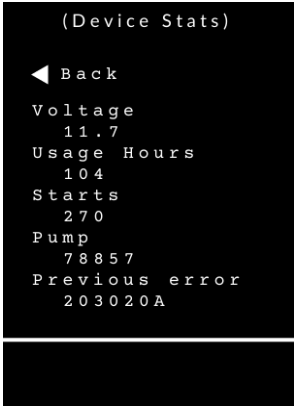
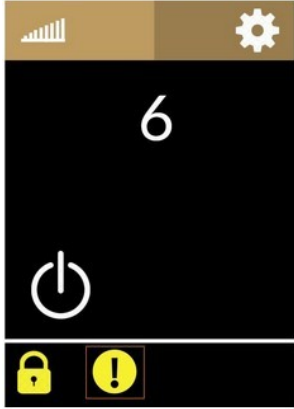
Note! Cooling procedure takes several minutes, before stove can be started again (long press is for safety).

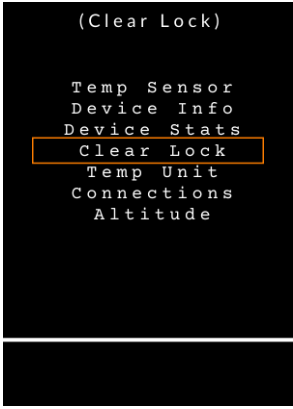
Settings			
			
<p>Move the selection square to the Main Menu Bar and press the Select Button. Use the Arrow Buttons to choose Settings. Press the Select Button.</p>	<p>Use the Arrow Buttons to move the selection square down and press the Select Button to choose.</p>	<p>Temp Sensor Note! Temp sensor selection is not valid for stoves. Selection must be wired.</p>	<p>Device Info - Control panel and stove software versions (needed for customer service/tech help) - Serial number of the device (needed for customer service/tech help)</p>

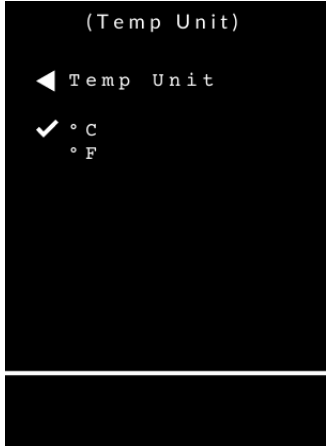
Settings			
			
<p>Device Stats</p> <ul style="list-style-type: none"> - Check there is enough voltage to start the unit (must have at least 11 V) - Check usage hours (units must be serviced every 2000 hours/3 years) - System starts - Pump cycles since new - Previous error code 	<p>If a Lock Icon is displayed, the device has locked itself for safety. The unit will also lock after 3 unsuccessful starts. Move the selection square to the Exclamation Point Icon and press the Select Button. An error Page will appear.</p>	<p>If the device has locked itself, there may have been a failure that should be investigated and resolved prior to further use. The error page will display a check list and a website for further information. If you need help, reach out to a professional.</p>	<p>To remove the lock, move the selection square to the Main Menu Bar and press the Select Button, choose Settings, and press the Select Button. Choose Clear Lock from the Settings Menu and press the Select Button.</p>

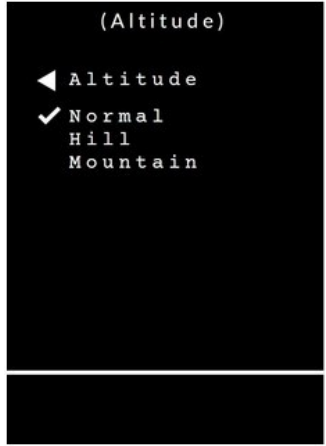
Settings			
			
<p>Temp Unit</p> <ul style="list-style-type: none"> - select temperature unit Celsius / Fahrenheit. Not used in stoves. 	<p>Connections</p> <p>Using stove with mobile application is not allowed for safety reasons.</p> <ul style="list-style-type: none"> - clear all paired mobile phone devices. 	<p>Adjust combustion in high altitudes. Stove operation can be optimized to different altitudes.</p>	

Connecting with the Remote application (stove)

Local Connection

Advanced Control Panel can be connected into the mobile application with local connection. First, download the "Wallas Remote" application to your mobile device from your application store. Note! For safety reasons the stove can not be started or used remotely by the mobile application. Wallas remote application can be used only for software update purposes.

Pairing the application with the stove/control panel

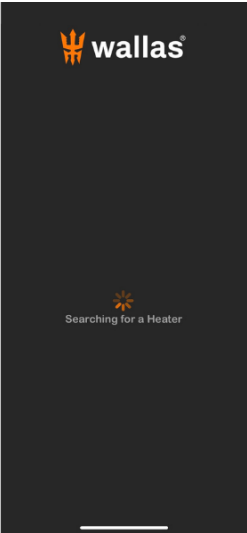
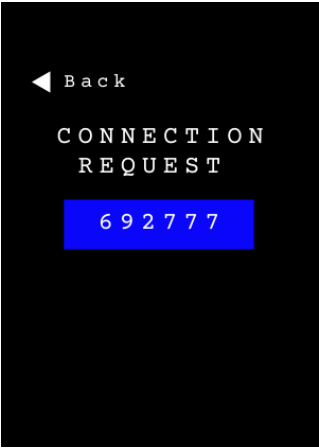
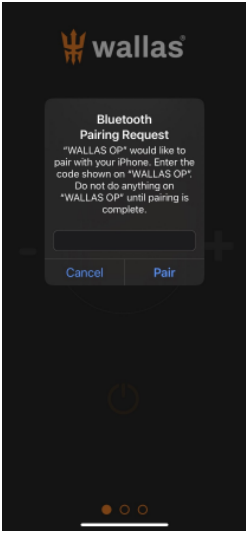
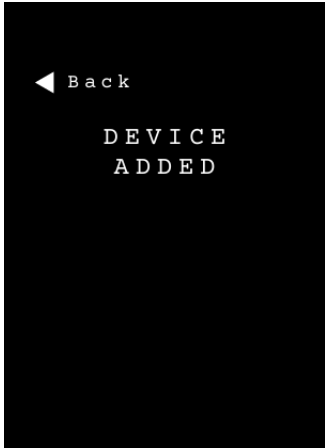
Mobile Device	Advanced Control Panel	Mobile Device	Advanced Control Panel
			
<p>Turn the short range wireless connection on from your mobile device for pairing. When you open the app for the first time, it will search for a Wallas device nearby.</p>	<p>When a device is found , a pin code will appear on the screen of the Advanced Control Panel.</p>	<p>Type the pin code in the app and press Pair to continue. Note! In some phone models Pairing request will open in background info window.</p>	<p>Once the pairing has been successful, it is confirmed on the Control Panel with <i>Device Added</i>.</p>

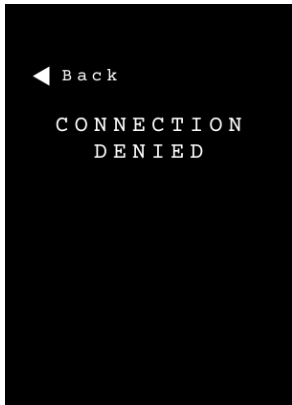
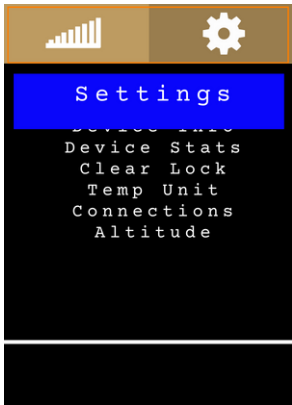
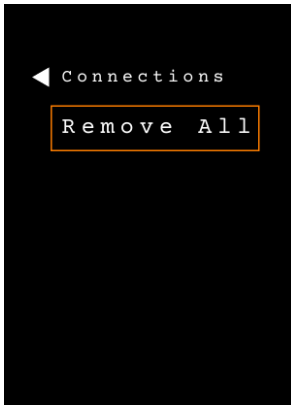
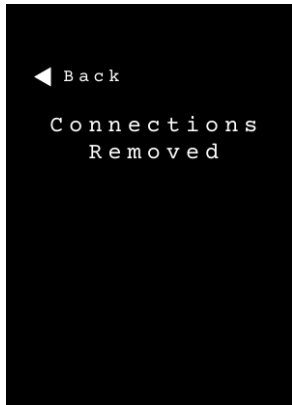
Advanced Control Panel	Advanced Control Panel	Advanced Control Panel	Advanced Control Panel
			
<p>If the connection was not successful, <i>Connection Denied</i> will appear on the Control Panel.</p>	<p>Use Arrow Buttons to go to the Main Menu Bar and press the Select Button. Go to the Settings and press the Select Button.</p>	<p>Choose Connections and press the Select Button. Select Remove All and press the Select Button.</p>	<p>Turn the app off, open it again and repeat the pairing process.</p>

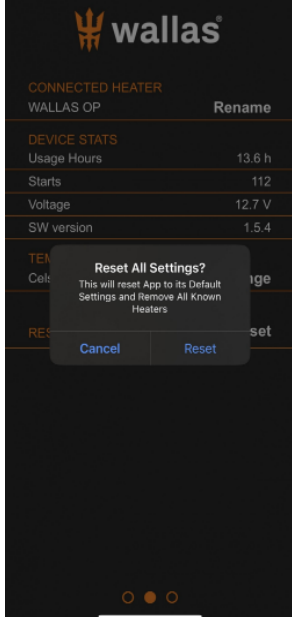
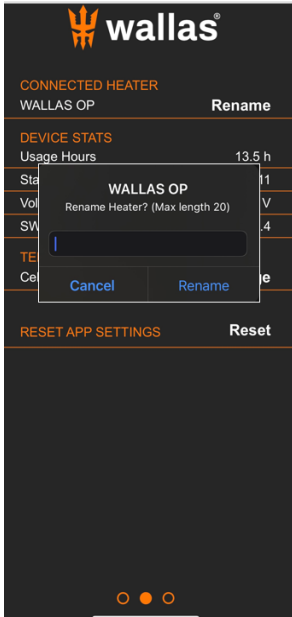
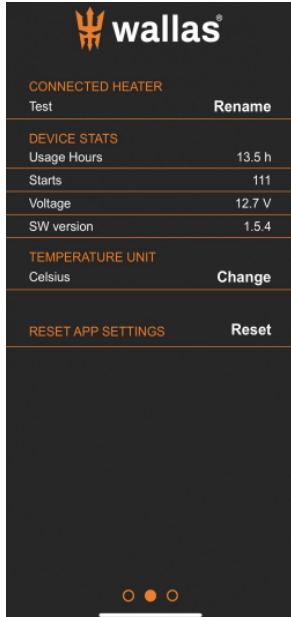
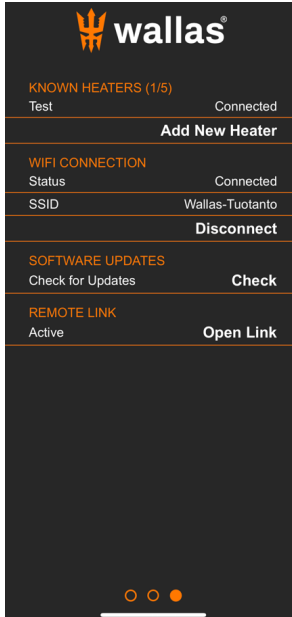
Mobile Device	Mobile Device	Mobile Device	Mobile Device
			
<p>Swipe the screen to the 2nd page.</p> <p>Default settings can be returned by pressing Reset and answering Reset to the appearing follow-up question.</p>	<p>When the device is connected for the first time it will be named by Wallas OP. Each device/connection can be renamed (max 20 characters).</p>	<p>User can add new device and repeat the pairing process with the new heater.</p>	<p>Swipe the screen to the 3rd page.</p> <p>Application supports up to 5 different unit connections. It is also possible to pair same unit with another mobile device but only one active user (active connection) is possible at a time.</p>

WiFi Connection

The 3009 Control panel can be connected to the internet with a WiFi connection.

Wifi connection is created through the Wallas Remote application. (Local connection between application and Control Panel must be available before setup)

The first time selecting Connect, the application will ask for SSID and Password. Application will share this information with Control Panel.

NOTE! "Open" WiFi or "no-password" networks will not work with the Wallas system.

NOTE! If you sell your heater or give it away, you need to clear WiFi settings. (SSID="empty", password="empty") and you should remove the Wallas application from your device.

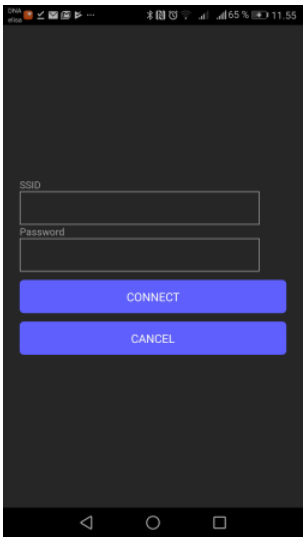
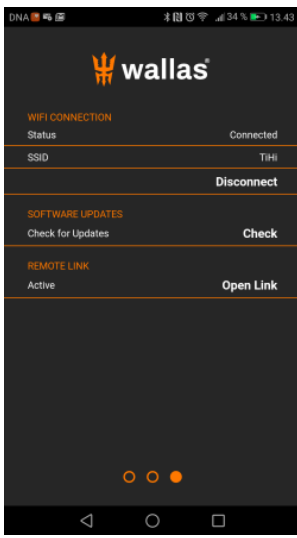
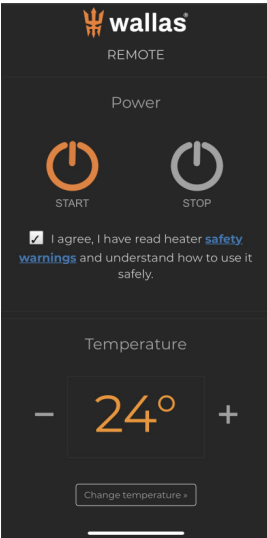
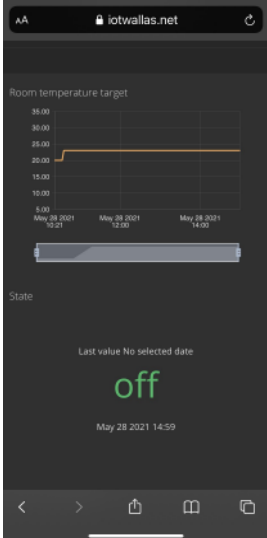
			
<p>Feed your internet connection details.</p>	<p>When internet connection is finalized status will be "connected". After few minutes "REMOTE LINK" will appear .</p>	<p>"REMOTE LINK " display will connect to internet panel. Note! Stove remote usage is not supported.</p>	<p>You can see when device was last connected into internet, and what the device state is. You can see some statistics of your device. Available graphs will vary depending of the model.</p>

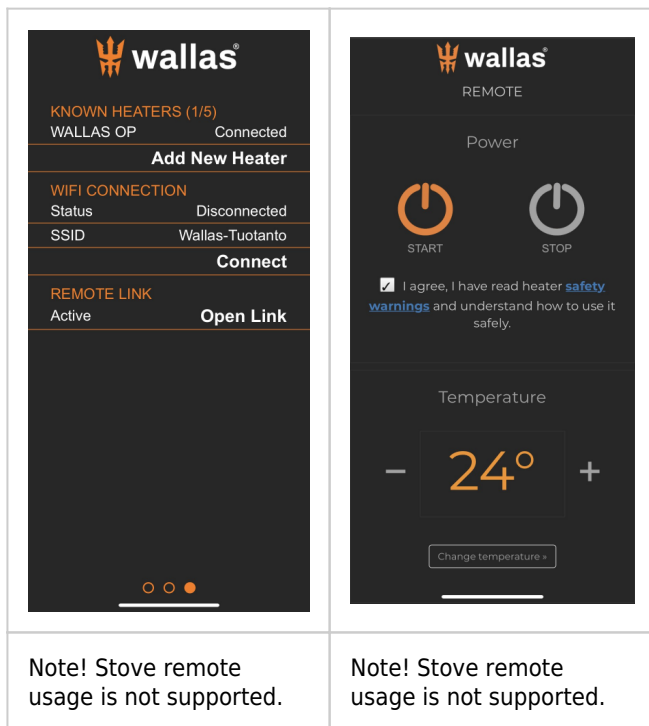

Wallas-Marin reserves the right to develop usability and features of the application.

Connections tips:

1. Read from your mobile device user guide how connections and WiFi connections are managed in your device.
2. Make sure that local connections and WiFi are allowed in you mobile device (airplane mode is OFF).
3. Your mobile device is not in power save mode and location permission is given to Wallas application.
4. Check that device is connected to power and Control panel is connected via cable to the heater.
5. Distance between Mobile device and Control Panel is not too long.
6. Control Panel is not in use by another person. Only one local connection is possible at a time.
7. If your mobile device already has connection to the heater it can not create new connection before the old connection is removed from your device. In some phone models this has to be made manually. Remove "WALLAS OP" from your phones paired short range wireless connection devices list (note there might be several OP pairings in mobile device list, remove all) and restart short range wireless connection before new pairing is possible. This may be the case if control panel pairing code only blinks fast and your mobile device is repeating the connection requests.
8. Change connection to other Wallas heater.
 - Close Wallas remote application.
 - Remove old connections from your mobile device short range wireless connection paired devices list. Restart your devices short range wireless connection.
 - If there is no other users for new Wallas heater you can select Control panel menu Settings/Connections/Remove all.
 - Restart application.
 - When/if "Change Device " link appears (30-60 sec) press the link.
 - Wait connection procedure to finalize.
9. In some phone models Pairing request will open in background info window. (See your mobile devices user guide.)

Software update

It is recommended to check software updates and perform software updating regularly to ensure optimal performance of the device.

Preparations for software update
<ol style="list-style-type: none"> 1. check that the device and the cell phone have sufficient level of power in battery 2. check that the WiFi signal is strong and the internet connection is reliable 3. be prepared to disconnect control panel cable, or power of the device to make master reset to the system if necessary



Software update is a complex process, and errors may happen if there is a power or network failure during the update, including complete system failure. Therefore it is forbidden to start software update for control panel if the Wallas heater is the only heat source and being unable to start heater would create a danger.

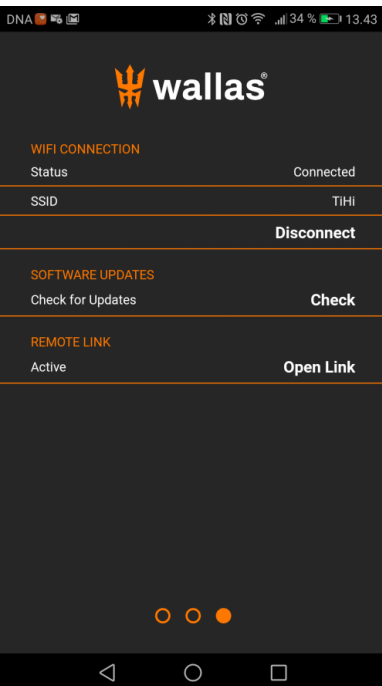

For software update make sure that

- WiFi signal is strong and the internet connection is reliable
- WiFi HotSpot name (SSID) is visible in application page and the status is "Connected"
- the heater is "OFF" before starting the update

Updating may take up to 6 minutes, depending on network and connection.

If new software version is available *Update link* will appear on the screen. Select update. Do not close application or power from the heater/stove while update is ongoing. Control panel display will close and start a few times during the update. After the update is done, control panel will start and application will reconnect to panel.

Note: In some phone models you may have to do the pairing again after software update.

Possible problem/error	Solution
<i>File error</i> message appears	Start update again after few minutes
Software update stops during download	<ol style="list-style-type: none"> 1. Close the application 2. Restart the short-range wireless connection from your mobile device 3. Start update again <p>Tip! Find different location, where WiFi signal is better or WiFi hotspot has a better connection</p>
Control panel is jammed	Disconnect panel cable and try again after few minutes

Error Codes

Possible error codes are listed on the table below.

Combined Code	Error message	Problem	Troubleshooting
10A06	Ignition failed	Ignition failed, maximum allowed number of pump pulses	Check the fuel, check the fuel filter, tighten all joints.
1020B	Low voltage	Supply voltage is below minimum	Renew/charge the battery.
10001	System error		Contact service
10003	System error		Contact service
10201	System error	Unexpected flame-out	Check the fuel level, check the fuel filter.
10206	Ignition failed	Preheating failed, residual fuel burning for too long	Try to start again, if same fault, contact service.
20005	System error		Contact service
20A0207	System error	Water thermostat is missing water temperature data	Contact service
20B0205	System error	Analog control (potentiometer) is missing	Connect the controller, check control panel wiring.
203020A	Ignition failed	No fuel was detected, maximum allowed number of pump pulses	Check the fuel, check the fuel filter, tighten all joints.
2010204	Combustion fan	Burner fan is not working (no tachometer signal)	Contact service
2020204	System error	Ventilation fan is not working (no tachometer signal)	Contact service
2030204	System error	Fuel pump output short-circuit	Fuel pump wires are in shortcut, check the wiring.
2030205	System error	Fuel pump not connected (no current detected on output)	Fuel pump is missing, connect fuel pump connector.
2040205	Water pump	Water pump is missing (no load on output)	Connect the water pump connector.
2050204	System error	Burner or ventilation fan power short-circuit	Contact service
2060204	Glow plug	Glow plug short-circuit	Renew the glow plug.
2060205	Glow plug	Glow plug missing (no current detected on output)	Renew the glow plug, check that the glow plug connector is connected to the ECU.

2070005	System error		Contact service
2080001	System error		Contact service
2080006	System error		Contact service
2080008	System error		Contact service
2080208	System error		Contact service
3000007	Burner temp sensor	Burner temperature is missing/invalid	Contact service
3010007	Air temp sensor	Air temperature is missing/invalid	Connect air temperature sensor.
3010202	Air overheat	Air temperature is too high	Check air vent's and warm air hoses for blockages.
3020004	Warning	Hot water target should not be set higher than coolant target	Adjust the hot water target from settings
3020007	Water temp sensor	Water temperature is missing/invalid	Contact service
3020202	Coolant overheat	Coolant temperature is too high	Coolant is not circulating, bleed the air out of the system, check the coolant pump.
50001	System error	CAN bus other errors	Contact service
50006	System error	CAN bus timeout error	Contact service
50008	System error	CAN bus busy error	Contact service
7020B	Low voltage	Cannot start, low voltage	Renew/charge the battery
7020C	System error	Cannot start, device locked	Open locking mode from the control panel, check control panel user manual.
7020D	System error	Cannot start, enable input not asserted	Enable wire is missing, connect the enable wire or set the main power ON
7020E	System error	Cannot start, burner temperature missing or too high	Powercut during the operation, Wait that unit cools down and try to start again.

Installation check list

Installation check list before test-run

Installation
<ul style="list-style-type: none">• Read manual and use only official Wallas parts.• Ensure sufficient air ventilation for the device, minimum aperture of 150 cm² (24 sq. in.) into installation area or use ventilation kit.• Ensure that the boat/cottage/location is sufficiently ventilated.• The exhaust pipe outlet must be at least 400mm (16") away from the opening for filling fuel or tank breather.• We recommend installing the control panel on a vertical surface where liquids are not able to leak into the switch and it is out of reach of children.• In metal-hulled boats stray current galvanic corrosion and electrochemical corrosion has been prevented by using floating installation method.
Fuel system
<ul style="list-style-type: none">• Fuel for the device comes through a separate tank fitting, not via a manifold or connection shared by the engine or other device.• Install the filter to the fuel hose before you install the device, in an accessible location for filter changes.• Fasten the fuel hose couplings tightly. Always use a sleeve joint on the hose (olive ring).• Make sure that the surfaces of the couplings are clean before fastening them.• The hoses must be kept clean during installation.• If the surface of the fuel tank is above the device, a magnetic valve must be installed into the fuel hose close to the tank.• Cut the fuel hoses to the appropriate length when installing them.
Electrical installation
<ul style="list-style-type: none">• The nominal voltage of the device is 12 VDC.• Current for the device is taken directly from the battery terminals using cables that are as short as possible.• Put the main fuse of c. 15 A on the + cable close to the battery.
Exhaust fumes
<ul style="list-style-type: none">• When choosing the outlet location, note that exhaust fumes are hot.• When installing to boat use a goose-neck in exhaust pipe to prevent splash water entering.• If your installation location is a boat with metal hull, the device and outlet must be insulated from the hull to prevent electrochemical corrosion.• The exhaust pipe must not come into contact with combustible materials. Insulate the exhaust hose, if necessary.
Initial start-up
<ul style="list-style-type: none">• The device usually does not start the first time after it has been installed. It may take several starts (c. 4-6) for the fuel hoses to fill up enough for the fuel to reach the burner.• Watch the hoses as they fill up as you start the device.• After two unsuccessful start-ups, the device will lock.• Follow the instruction for unlocking the device and try again.• When the device starts, look for possible leaks in the exhaust and fuel connections.• Run the device for c. ½ hour to allow possible installation and manufacturing greases to burn off. Make sure there is enough ventilation.• NOTE! Remember to carefully read the instructions for installing, operating and servicing each device before installation.



In metal-hulled boat, you must ensure that the device, the flue gas lead-through, the fuel connection, the control panel and all other parts are insulated from the boat's hull. This must be done to prevent electrochemical corrosion and to prevent voltage from being transmitted from the hull to the device or vice versa during electrical faults.

To be filled in by the installer

Test-run performed	
Serial number	
Company	
Installer	
Installation date	
Signed	

Maintenance recommendations for stoves



Service recommendation for the stove is 2000 operating hours or every 3 years, whichever comes first.



Maintenance should be carried out by authorized Wallas service shop.

Special recommendations

Occasional (monthly) use of the device will increase reliability by purging old fuel. Observe fuel provider recommendation with regard to the fuel type, fuel life length, additives and moisture removal.

If the device has a separate tank:

When selecting the fuel type, take note of the temperature limits of each particular fuel.

Removal of the water from the tank

Isopropanol based anti ice detergent meant for gasoline cars (no ethylene or methyl based) will be added to the fuel during the season. It is useful to make the addition after each couple of tanks and in the beginning and end of the heating season. The anti ice detergent binds the condensed water and prevents the sediment and contamination during the summer. For the dosage, observe the recommendations given by the manufacturer of the agent.

Winter storage

If the device uses the same tank as the engine:

- Change the fuel filter.
- Perform measures recommended by the boat/engine manufacturer to be performed before winter storage.

If the device has a separate tank:

- Drain the fuel tank in the autumn.
- Clean the tank and change the fuel filter.
- Fill the fuel tank with fresh and clean fuel in the spring.

For the device itself, you do not need to do anything.

Spare parts

Spare parts list, www.wallas.com



An anti-freezing agent for diesel vehicles may increase the forming of scale at the bottom of the burner and therefore shorten the maintenance interval.

Warranty terms

Wallas-Marin Oy (the “Manufacturer”) warrants their heaters, stoves, and ovens (hereinafter referred to as the “Product”), against defects in material and workmanship for two (2) years or 2,000 operating hours in normal use (whichever comes first) effective at the time of sale to the Original End-User under the conditions provided herein.

Wallas-Marin heating systems are designed and intended for recreational use. Use for commercial, live-aboard or unattended use will result in elevated operating hours requiring maintenance and repair not covered by product warranty.

1)	This warranty is made only to the first purchaser/customer (“Original End-User”), who acquires the Wallas-Marin Product for their own use.
2)	This warranty will be in effect for two (2) years or 2,000 operating hours (whichever comes first) from the date of purchase by the Original End-User. A copy of the dated receipt of the sale should be retained as evidence of the date of purchase. The warranty period may be extended by an additional 12 months by registering the Product within three (3) months of the Product being sold to the Original End-User. Registration must be done online at www.wallas.fi/takuu . Despite the extended warranty period, coverage is limited to 2,000 operating hours for all Products. Repairs carried out during the warranty period do not renew or alter the original warranty period.
3)	The intent of this warranty is to protect the Original End-User of the Product from defects and provide repair and replacement of defective parts. Warranty repair service must be administered by an authorized Wallas-Marin distributor or an authorized Wallas-Marin Service Center in accordance with the Wallas-Marin warranty policy.
4)	Notification of the defect must be given in writing immediately to the authorized Wallas-Marin distributor, that sold the product (the “Seller”) by the Original End-User, if possible, but no later than two (2) months after the defect occurred. If the warranty period has expired and no notice was given in writing while the warranty was still valid, the defect will not be covered.
	The notification must include: <ul style="list-style-type: none"> • Description about the issue • Description about the installation, when, where, and by whom it was done (photographs may be included) • Product name, serial number, place and date of purchase
5)	For repairs under warranty, the Original End-User must take or package and ship the product to an authorized Wallas-Marin Distributor or to an authorized Wallas-Marin Service Center. The best location for repairs is determined by the importer after the Original End-User has notified the Seller about the issue. Once the Wallas-Marin Distributor/Service Center has examined the returned Product and if it is found that it was defective in material and/or workmanship, the Distributor/Service Center shall repair the product. If the distributor/Service Center determines that repairs must be made, only authorized Wallas-Marin parts will be used.
6)	This is a Return to Base Warranty, which does not cover costs accumulated from the removal and re-installation of the Product, or transportation costs if the Product has been shipped for repairs, or any damage occurred in transit.
7)	This warranty does not cover consumable or wear parts, which include glow coil/plug, bottom mat or wick, fuel filter, seals.
8)	This warranty does not limit the rights specified in the consumer protection legislation.

9)	<p>This warranty does not cover indirect damages arising from a defective Product, property damage, loss of revenue, injury or loss of life as a result of system failure, or conditions unrelated to the material and workmanship of the Wallas-Marin Product.</p> <p>Such unrelated conditions include, but are not limited to:</p> <ul style="list-style-type: none"> a) The Product has not been installed according to the Wallas-Marin Product User Manual or the country-specific regulations have not been followed. b) Damage or failure caused by installation of accessories or components not manufactured or approved by Wallas-Marin and/or modification of the Product structure without the consent of the Manufacturer. c) Failure to follow the operation or maintenance instructions in the Product User Manual. d) Damage caused by inappropriate storage or transport. e) Fault resulted by an accident or damage of which Wallas-Marin had no control over (force majeure). f) Damage or failure caused by improper handling, use of unsuitable fuel, low voltage, excess voltage, dirt, water penetrating the Product, galvanic corrosion, electro chemical corrosion or damages due to stray current. g) The Product has been dismantled or opened without the explicit permission of the Manufacturer/Importer. h) Non-Wallas components or spare parts have been used in the repair of the Product. i) Repair was done by an unauthorised service provider. j) Installation error when possible leaking water or leaking coolant can enter the boat/vehicle/RV/building structures.
10)	<p>Wallas-Marin is not responsible for any damages to a boat/vehicle/RV/building or property due to Wallas unit is/is not working properly whatsoever.</p>
11)	<p>Wallas-Marin reserves the right to change the design of any Wallas-Marin Product without notice and with no obligation to make corresponding changes in Wallas-Marin products previously manufactured.</p>

	<p>When making a warranty claim, the Original End-User must provide proof that the maintenance and safety instructions have been thoroughly followed. This warranty does not apply to defects which have risen due to carelessness in following installation, operation, and maintenance instructions.</p>
---	---

Disclaimers

<p>The manufacturer is not liable for damage caused by improper use or incorrect operation or installation. Failure to comply with the installation, operation and service instructions makes the warranty null and void and this leads to the exclusion of any liability of Wallas-Marin Oy.</p>
<p>The manufacturer does not cover any indirect damages arising from a Product, property damage, loss of revenue, injury or loss of life, or conditions unrelated to the material and workmanship of the Wallas-Marin Product. Such conditions include, but are not limited to: colder-than-expected weather or instances where the Product fails to maintain the temperature, leading to frozen water pipes and subsequent leaks, ruining the property of the user.</p>

